



RE – 2554
RE – 2558

Automatic Fire Alarm Control Panel
(Protective premises Unit)

Installation, Commissioning & Operating
User Manual

Fire Alarm System Limitations

An automatic fire alarm system—typically made up of smoke detectors, heat detectors, manual Call Points, audible warning devices, and a fire alarm control with remote notification capability—can provide early warning of a developing fire. Such a system, however, does not assure protection against property damage or loss of life resulting from a fire. The Manufacturer recommends that smoke and/or heat detectors be located throughout a protected premise following the recommendations of the current edition of the National Fire Protection Association Standard 72 (NFPA 72), manufacturer's recommendations, State and local codes, and the recommendations contained in the Guide for Proper Use

of System Smoke Detectors, which is made available at no charge to all installing dealers. A study by the Federal Emergency Management Agency (an agency of the United States government) indicated that smoke detectors may not go off in as many as 35% of all fires. While fire alarm systems are designed to provide early warning against fire, they do not guarantee warning or protection against fire. A fire alarm system may not provide timely or adequate warning, or simply may not function, for a variety of reasons:

Smoke detectors may not sense fire where smoke cannot reach the detectors such as in chimneys, in or behind walls, on roofs, or on the other side of closed doors. Smoke detectors also may not sense a fire on another level or floor of a building. A second-floor detector, for example, may not sense a first-floor or basement fire.

Particles of combustion or "smoke" from a developing fire may not reach the sensing chambers of smoke detectors because:

- Barriers such as closed or partially closed doors, walls, or chimneys may inhibit particle or smoke flow.
- Smoke particles may become "cold," stratify, and not reach the ceiling or upper walls where detectors are located.
- Smoke particles may be blown away from detectors by air outlets.
- Smoke particles may be drawn into air returns before reaching the detector.

The amount of "smoke" present may be insufficient to alarm smoke detectors. Smoke detectors are designed to alarm at various levels of smoke density. If such density levels are not created by a developing fire at the location of detectors, the detectors will not go into alarm.

Smoke detectors, even when working properly, have sensing limitations. Detectors that have photo electronic sensing chambers tend to detect smoldering fires better than flaming fires, which have little visible smoke. Detectors that have ionizing-type sensing chambers tend to detect fast-flaming fires better than smoldering fires. Because fires develop in different ways and are often unpredictable in their growth, neither type of detector is necessarily best and a given type of detector may not provide adequate warning of a fire.

Smoke detectors cannot be expected to provide adequate warning of fires caused by arson, children playing with matches (especially in bedrooms), smoking in bed, and violent explosions (caused by escaping gas, improper storage of flammable materials, etc.).

While a fire alarm system may lower insurance rates, it is not a substitute for fire insurance!

Heat detectors do not sense particles of combustion and alarm only when heat on their sensors increases at a predetermined rate or reaches a predetermined level. Rate-of-rise heat detectors may be subject to reduced sensitivity over time. For this reason, the rate-of-rise feature of each detector should be tested at least once per year by a qualified fire protection specialist. *Heat detectors are designed to protect property, not life.*

IMPORTANT! Smoke detectors *must be installed in the same room as the control panel and in rooms used by the system for the connection of alarm transmission wiring, communications, signaling, and/or power.* If detectors are not so located, a developing fire may damage the alarm system, crippling its ability to report a fire.

Audible warning devices such as bells may not alert people if these devices are located on the other side of closed or partly open doors or are located on another floor of a building. Any warning device may fail to alert people with a disability or those who have recently consumed drugs, alcohol or medication.

Please note that:

- Strobes can, under certain circumstances, cause seizures in people with conditions such as epilepsy.
- Studies have shown that certain people, even when they hear a fire alarm signal, do not respond or comprehend the meaning of the signal. It is the property owner's responsibility to conduct fire drills and other training exercise to make people aware of fire alarm signals and instruct them on the proper reaction to alarm signals.
- In rare instances, the sounding of a warning device can cause temporary or permanent hearing loss.

A fire alarm system will not operate without any electrical power. If AC power fails, the system will operate from standby batteries only for a specified time and only if the batteries have been properly maintained and replaced regularly.

Equipment used in the system may not be technically compatible with the control. It is essential to use only equipment listed for service with your control panel.

The most common cause of fire alarm malfunction is inadequate maintenance. To keep the entire fire alarm system in excellent working order, ongoing maintenance is required per the manufacturer's recommendations, and UL and NFPA standards. At a minimum, the requirements of NFPA 72 shall be followed. Environments with large amounts of dust, dirt or high air velocity require more frequent maintenance. A maintenance agreement should be arranged through the local manufacturer's representative. Maintenance should be scheduled monthly or as required by National and/or local fire codes and should be performed by authorized professional fire alarm installers only. Adequate written records of all inspections should be kept.

NOTES:

It is imperative that the installer understands the requirements of the Authority Having Jurisdiction (AHJ) and be familiar with the standards set forth by the following regulatory agencies:

- Underwriters Laboratories Standards
- NFPA 72 National Fire Alarm Code

NFPA Standards

This Fire Alarm Control Panel complies with the following NFPA Standards:

NFPA 72 National Fire Alarm Code for Local Fire Alarm Systems.

Underwriters Laboratories Documents for Reference:

- UL 38 Manually Actuated Signaling Boxes
- UL 217 Smoke Detectors, Single and Multiple Station
- UL 228 Door Closers–Holders for Fire Protective Signaling Systems
- UL 268 Smoke Detectors for Fire Protective Signaling Systems
- UL 268A Smoke Detectors for Duct Applications
- UL 346 Waterflow Indicators for Fire Protective Signaling Systems
- UL 464 Audible Signaling Appliances
- UL 521 Heat Detectors for Fire Protective Signaling Systems
- UL 864 Standard for Control Units for Fire Protective Signaling Systems
- UL 1481 Power Supplies for Fire Protective Signaling Systems
- UL 1638 Visual Signaling Appliances
- UL 1971 Signaling Devices for Hearing Impaired

Table of Contents

CHAPTER 1: Introduction	9
1.1: System Design & Planning	9
1.2: General	9
1.3: Fire Alarm Procedure	10
1.4: User Responsibility.....	10
1.5: Routine test.....	11
CHAPTER 2: Product Description	12
2.1: Product Features	13
2.2: Specifications	15
2.3: Controls and Indicators	16
2.3.1: Controls.....	16
2.3.2: Indication.....	17
2.3.2.1 LED Indication.....	17
2.3.2.2.: LCD Indication	18
2.3.2.3: Local Buzzer	18
2.4: Mechanical Construction.....	18
2.5: Internal Arrangement.....	19
2.6: Components	20
CHAPTER 3: Installation	22
3.1: Installation Precaution.....	22
3.2: Mounting Details	24
3.3: Panel Wiring.....	25
3.4: Initiating Device Circuits.....	30
3.5: Output Circuits	31
3.5.1: Notification Appliance Circuit	31
3.5.2: 24V Output.....	32
3.6: Standard Relay Output	33
CHAPTER 4: Programming Instructions	34
4.1: Menu Key Flow Diagram.....	34
4.2: Programming.....	36
4.2.1. Set Zone Mode.....	36
4.2.2. Suppressed Fault Events.....	39
4.2.3. Suppressed Supervisory Events	39
4.2.4. Zone Wiring.....	39
4.2.5. Supervisory Mode.....	40
4.2.6. Walk test.....	40
4.2.7. Auto Silence.....	40
4.2.8. Silence Inhibit.....	41

4.2.9. AC Loss Delay.....	41
4.2.10. Trouble Reminder	42
4.2.11. NAC1 Output.....	42
4.2.12. NAC2 Output.....	43
4.2.13. 24V Output.....	43
4.2.14. Change User Password	44
4.2.15. Change Admin Password	44
4.2.16. About	45
CHAPTER 5: Operating Instructions.....	46
5.1: Switch Functions	46
5.2: Indications	48
5.3: Operation.....	50
5.3.1: Normal Monitoring Mode.....	50
5.3.2: Fire Alarm Condition.....	50
5.3.3: Supervisory.....	51
5.3.4: Fault.....	53
5.3.5. Disable / W.T.....	53
5.3.6: Alarm Verification	55
CHAPTER 6: Servicing.....	56
6.1: Installation / Replacement of PCB.....	56
6.2: Lamp Test.....	58
6.3: Walk test.....	58
6.4: System Power	59
6.5: Trouble Shooting	60
CHAPTER 7: Calculation of Battery Size	61
CHAPTER 8: wire Requirement.....	62
CHAPTER 9: Compatible Devices	63
CHAPTER 10: Abbreviation.....	64

Chapter 1: Introduction

This manual is intended as a complete guide to the 4/8 Zone Conventional Fire Alarm Control Panels. This manual provides complete information on installation, commissioning, Operating Instructions, programming guide, service, and maintenance procedures with full technical details.

1.1 System Design and Planning

It is assumed that the system, of which this control panel is a part, has been designed by a competent fire alarm system designer in accordance with the requirements of NFPA – 72 and any other local codes of practice that are applicable. The design drawings should clearly show the positions of the field devices and the control equipment.

1.2 General

The panel is self-contained with integral power supply and space provision for two sealed lead-acid standby batteries and comply with the requirements of NFPA – 72. The panel's functions are microprocessor controlled and test and isolate functions are included. Provision is made for a repeater function of panel status output. The panel can accept, per zone, automatic detectors with a total maximum loading of 2mA quiescent current rating (refer to chapter 2.2), and an unlimited number of manual call points.

Installation

The panel is easy to install and operate. Control functions Programming functions are enabled by using password. The panel fascia is retained by tamper-proof screws.

1.3 Fire Alarm Procedures

In accordance with NFPA – 72, written procedures should be laid down for dealing with alarms of fire, fault warnings, and the isolation of any part of the system. The responsible person should ensure that users of the system are instructed in its proper use and are familiar with the procedures.

On hearing the fire alarm:

CARRY OUT THE PRESCRIBED PROCEDURE Subsequent actions will depend on the circumstances, and may include silencing the audible alarms and resetting the system, as described later.

To Evacuate the premises:

Press the Evacuate key and enter the password to OPERATE NAC's (Sounders).

Fault Indication:

If the control panel indicates a Fault condition, make a note of all illuminated indicators and proceed as described in chapter 6 (Section 6.4) or call service engineer.

1.4 User Responsibility

In addition to the routine testing described on routine test, the user has a responsibility for ensuring certain actions are taken following a fire or fault, and for implementing remedial action following a specified incidence of false alarms. As a minimum, the user shall record any incident and inform the service organization, who may be required to retest the system.

1.5 Routine Testing

In order to ensure that the system is fully operational, and to comply with the requirements of UL864 Standard & NFPA – 72, the following routine attention is recommended:

Daily - Check the panel to ascertain that it indicates normal operation. If any fault is indicated check that it has been recorded and the appropriate actions have been taken e.g. informing to the maintaining company.

Weekly - Test at least one detector or call point to confirm the operation of the panel and the audible alarms. Test a different zone each week and, if possible, a different device. Keep a record of the device and zone tested each week. Record and report any malfunction.

Quarterly - The responsible person should ensure that every three months the system is checked by a competent person. Check the standby batteries and the charger voltage Test at least one device in each zone to check the panel functions. Check the operation of the audible alarms and any link to a remote manned centre, Central Station, etc. Carry out a visual inspection of the installation to check for alterations or obstructions and issue a certificate of testing.

Annually - The responsible person should ensure that, in addition to the quarterly checks, each device on the system is tested and that a visual inspection is made of the cable fittings and equipment.

Note: The control panel cabinet should be cleaned periodically by wiping with a soft, damp cloth. **Do not** use any solvents.

Chapter 2: Product Description

The RE – 2554 & RE – 2558 is a 4 & 8zone microprocessor based conventional Fire Alarm Control Panel. The Panel accepts water flow devices, conventional input devices like 2 wire and 4 wire smoke detectors, Manual Call Points and other normally open contact devices. The Outputs include two notification appliance circuits (NACs), Resettable 24v D.C. output, Three Form –C relays for alarm, fault and supervisory. This panel is field programmable via the front panel keypad. It supervises all wiring, AC voltage and Battery level.

2.1 Product Feature

- 4/8 Class B initiating device circuit (IDC).
 - ❖ All zones accept smoke detectors and any normally open contact device.
 - ❖ Any Zone can be configured as Alarm or supervisory Zone.
- 2 Class B Notification Appliance Circuits (NAC).
- Fully complies with UL -864 and NFPA-72.
- Rugged CRCA sheet with powder coated finish.
- Operates on 110 - 220v 50 /60 Hz, AC Mains power supply.
- Standby (battery) backup 24v DC power supply with built in charger
- 16x2 Dot Matrix LCD Display.
- Error free Fire / Fault status in unambiguous colored LED indication.
- System ON indication.
- Main, Standby status audible and visual indication.
- Battery Low visual warning with audible tone.
- Form-C relays for fire, fault and supervisory.
- Resettable / uninterrupted 24v D.C. Output.
- RS 485 Communication facility (Optional).
- Lamp Test facility.
- Walk Test facility.
- Zone Isolation facility with loop voltage cut off.
- Earth fault annunciation facility at 0 ohms.
- All field wiring circuits are Power limited except 110 - 220v AC and Battery.
- All field wiring circuits are supervised.
- AC Low voltage cutoff.
- Programmable NAC's.
- Programmable IDC's.
- Programmable Supervisory Mode.
- Programmable AC loss delay.
- Alarm verification facility.
- Programmable Trouble reminder facility.

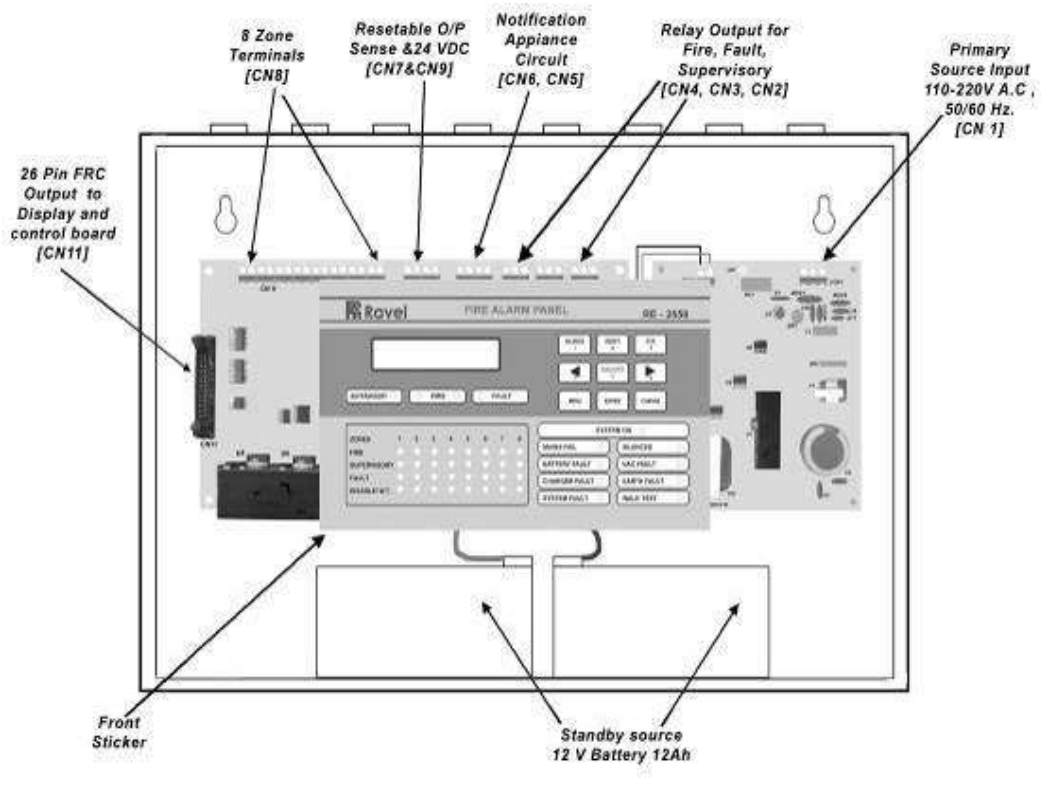

Figure – 1

2.2 Specification

Primary Power – CN1 (RE-SMPS-4A-R1)

110 - 220VAC \pm 10%, 50 Hz, 2.5Amps.

Standby Power – CN10

24v D.C (2 Nos of 12v, 12Ah Sealed Lead acid battery).

Operating Condition

Operating Temperature – 0 - 49° C/32-120° F.

Relative Humidity – 93 \pm 2% RH (non-condensing) at 32 \pm 2° C/90 \pm 3° F.

Charging Circuit

Charging Voltage – 28.2V, \pm 0.5V

Charging Current – 800mA (Max.).

Initiating Device Circuits – CN 8

All zones are Class B Style B/C operation (Programmable).

Normal Operating Voltage: 14 - 21 VDC.

Alarm Current: 15 – 30mA.

Short Circuit Current: 45mA Maximum.

Loop resistance: 100 ohms Maximum.

End-Of-Line Resistor: 3K9, 1/2watt

Standby Current: 7mA (2mA for Detectors)

Notification Appliance Circuits – CN5 and CN6

Class – B Style - Y wiring

Operating Nominal Voltage: 24VDC – Special Application

Current for all NACs: 1.2Amps (0.6A per circuit)

Current Limit: CN5 and CN6 via Thermal Fuse

Line Drop: 1.8V

End-Of-Line Resistor: 3K9, 1/2watt

Note:

For compatible devices refer Chapter 9(CD 01).

D.C. Power – CN7

Operating Voltage: Supervised 24VDC regulated, 300mA Max. (for 4 wire smoke detector)

Common Three Form – C Relays – CN2, CN3, CN4

Relay Contact Rating: 2Amps @ 30 VDC, 2Amps @ 30VAC.
Power Factor: 0.6

2.3 Control and Indication

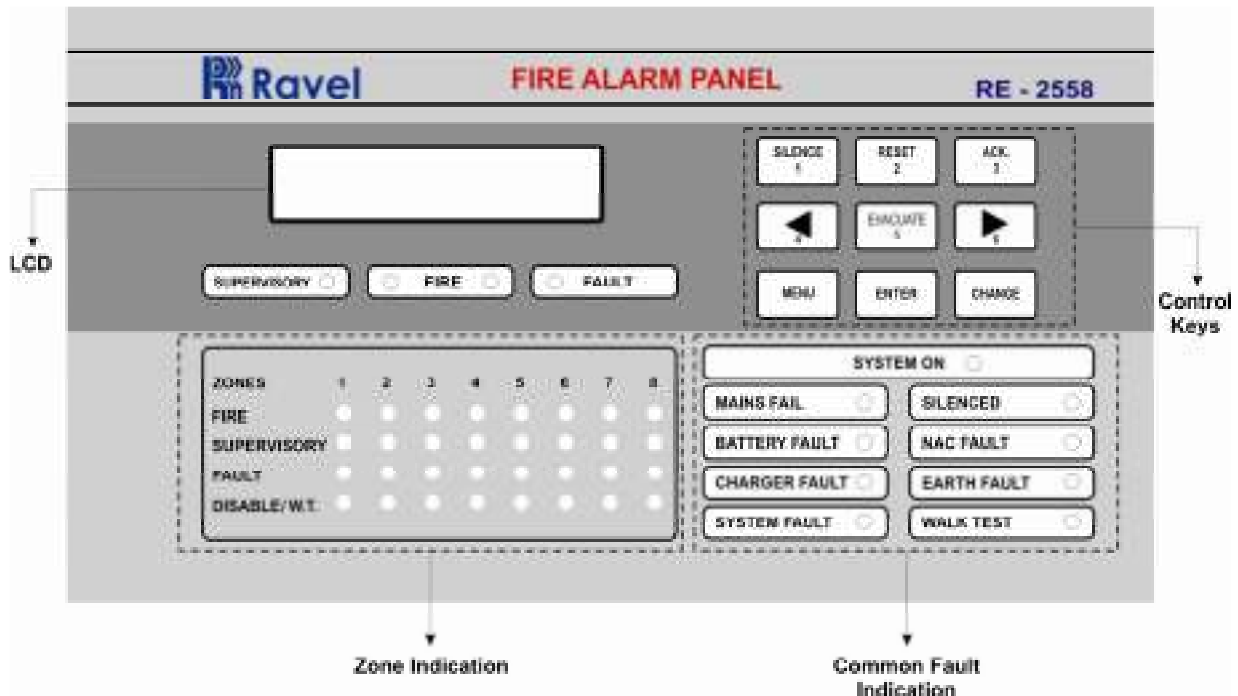

Figure – 2

2.3.1. Controls:

ACK. Key:

- ✓ To mute local buzzer in alarm condition.
- ✓ To mute local buzzer in Supervisory or fault condition.
- ✓ User or Admin password protected.

SILENCE Key:

- ✓ To silence the external NACs in Fire Condition.
- ✓ User or Admin password protected.

RESET Key:

- ✓ To reset the particular zones in Fire alarm or Latched Supervisory condition.
- ✓ User or Admin password protected.
- ✓ Possible to access only after silence in alarm condition.

EVACUATE:

- ✓ To activate External NACs Manually.
- ✓ User or Admin password protected.

CURSOR KEYS:

- ✓ To move the cursor point in the LCD as required.

ENTER Key:

- ✓ To accept the programmed or edited menu, mode or value in the LCD.

MENU Key:

- ✓ To enter into the Main Menu in the LCD.

CHANGE KEY:

- ✓ To change the status of modes.

2.3.2. Indications:**2.3.2.1 LED indication**

System On – Green
Fire – Red
Fault – Yellow
Supervisory – Yellow
Mains Fail – Yellow
Battery Fault – Yellow
Earth Fault – Yellow
System Fault – Yellow
Silenced – Yellow
NAC Fault – Yellow
Walk Test – Yellow
Charger Fault - Yellow
Zone Fire – Red
Zone Supervisory – Yellow
Zone Fault – Yellow
Zone Disable/W.T – Yellow

2.3.2.2 LCD Indication

The LCD is mainly used for the programming of the panel. It also indicates all events along with the LED indications except system on and system fault.

2.3.2.3 Local Buzzer

A piezo buzzer provides separate and distinct sounds for alarm, trouble and supervisory conditions:

- Alarm – Continuous
- Fault – pulse 0.5sec ON and 5sec OFF
- Supervisory – pulse 0.25sec ON and 0.25sec OFF

2.4 Mechanical Construction

The enclosure of the Panel is constructed by 18 gauge (1.22mm) CRCA sheet with powder-coated finish. The $\varnothing 22.25\text{mm}$ ($\varnothing 19\text{mm}$ [11No's] for Indian Std.) 10no's of knockouts are given for cable entry at the top of the cabinet. The lockable hinged door is provided to access the inside the cabinet. The panel also has sufficient space to accommodate 2 Nos. of 12v, 7Ah batteries.

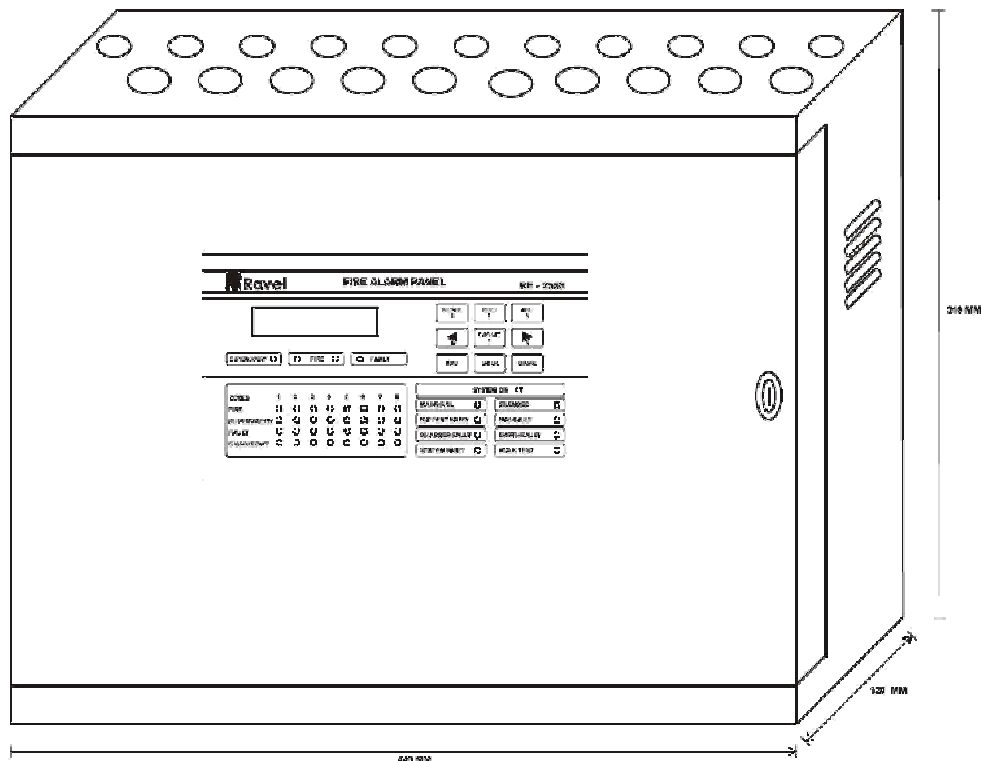

Figure – 3

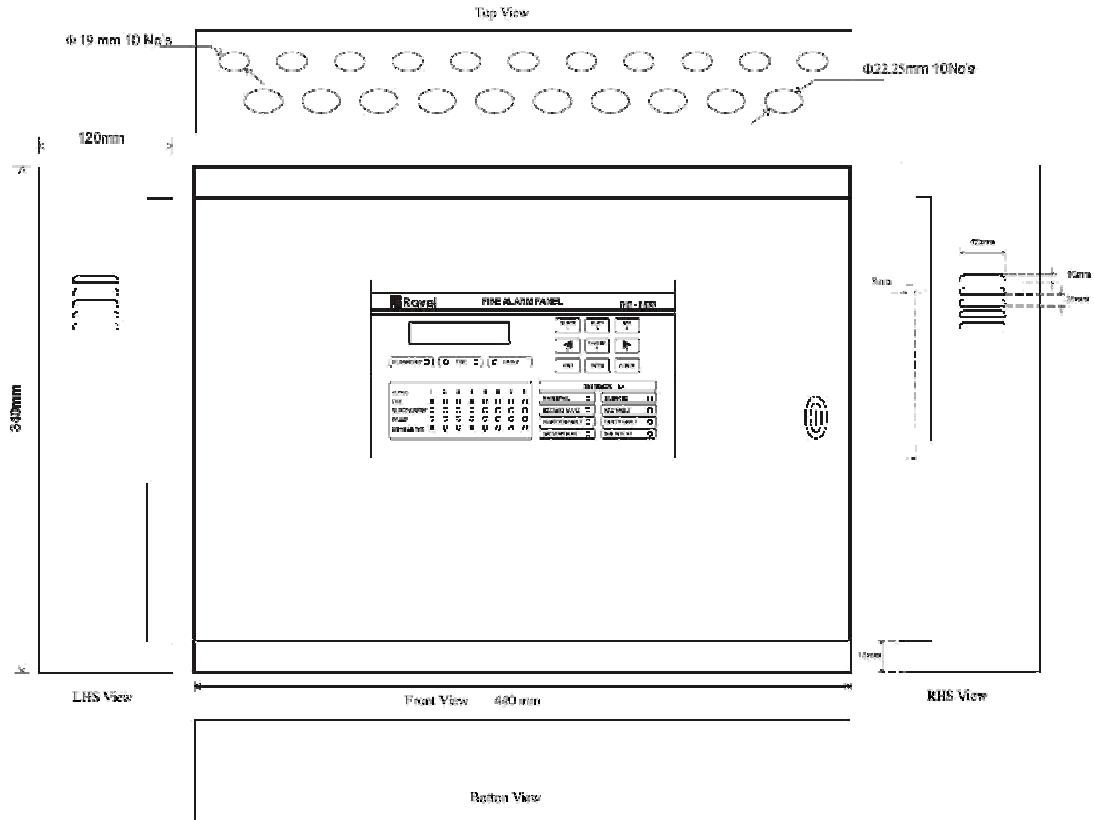

Figure – 4

2.5 Internal Arrangement

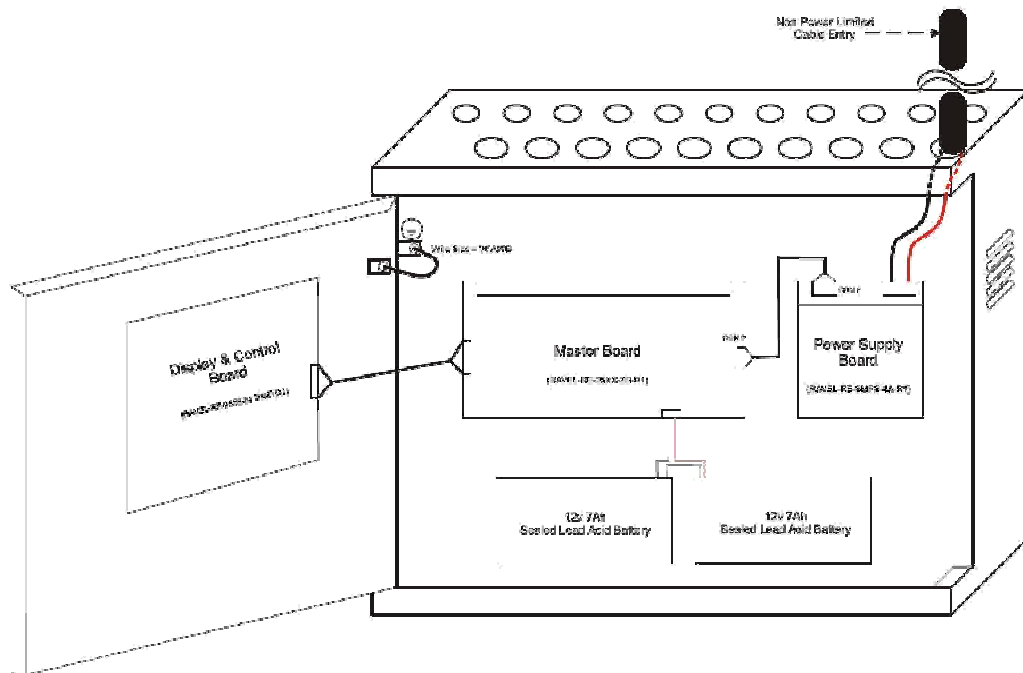

Figure – 5

2.6 Components

Master Board (RE – 25XX – ZB – R1)

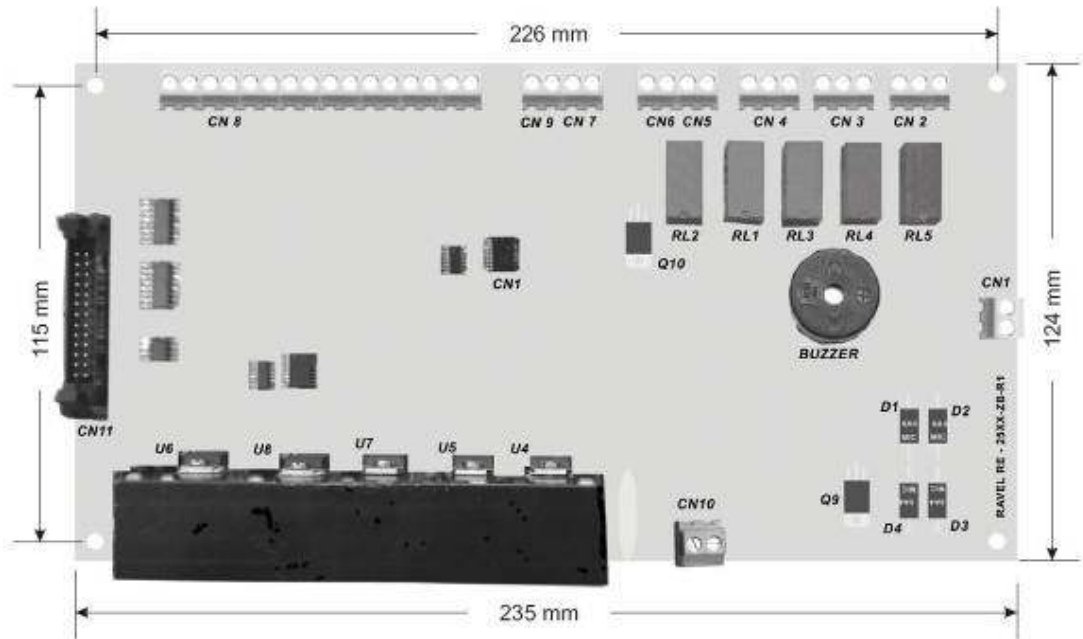

Figure – 6

The Zone board contains the primary components and wiring interface connectors.

Display Board (RE – 2558-54 – DISP – R1)

The Display Board contains the system CPU, LED Display, LCD unit and Control keys.

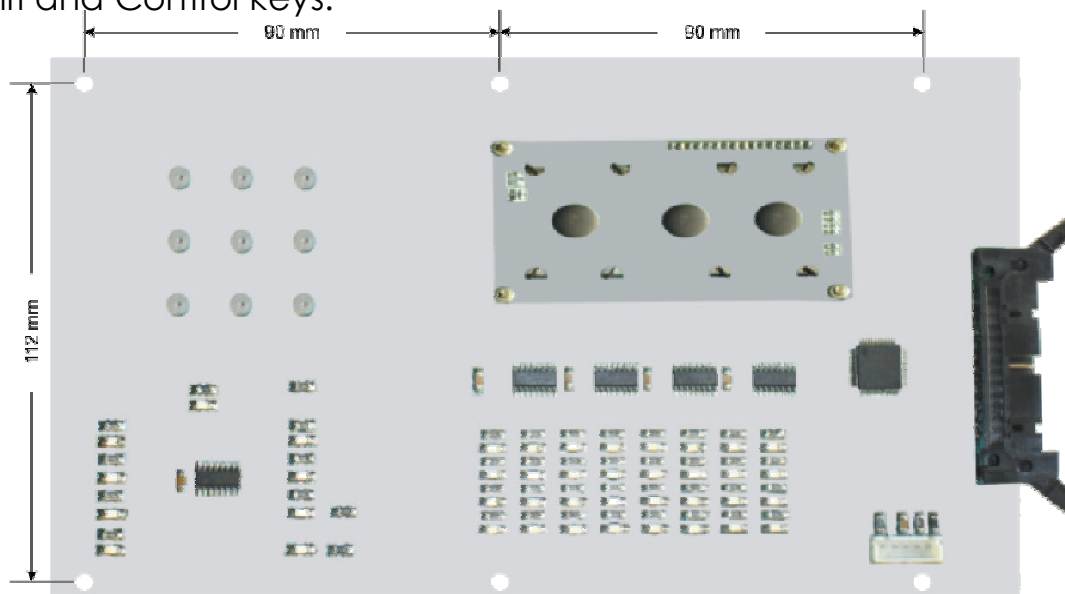

Figure – 7

Power Supply Board (RE – SMPS – 4A – R1)

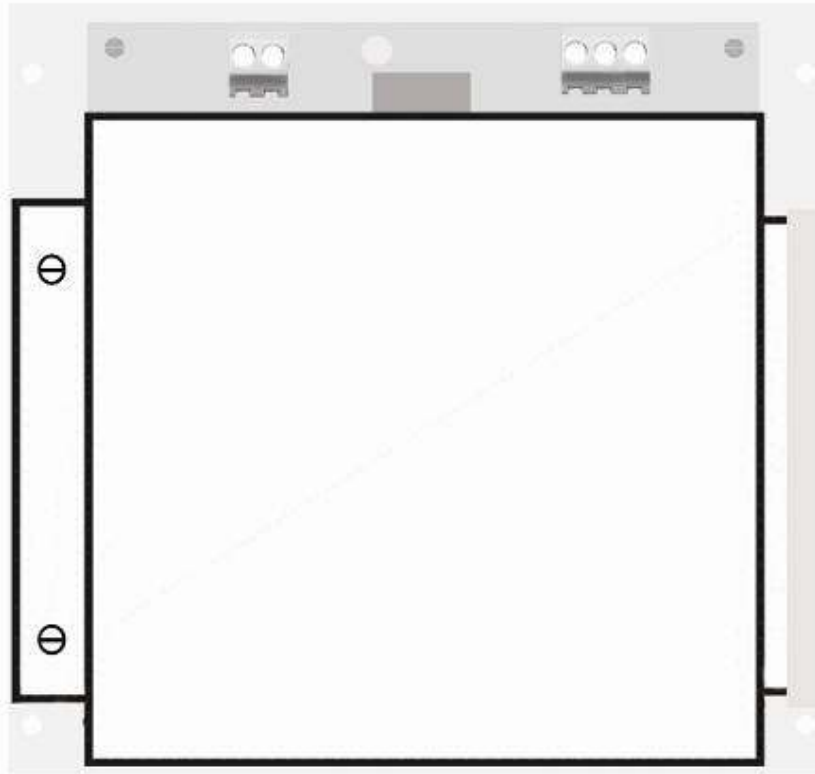

Figure – 8

This Power supply Board gives the 30V DC output for the Zone Board. This board is SMPS type, it gives the output for 2.5Amps Max (4Amp During Initial condition).

Cabinet

The Cabinet measures 440mm width X 340mm Height X 120mm Depth and space is provided for 2 x 12 Volt 7Ah Batteries, main circuit board and display board.

Chapter 3: Installation

3.1 Installation Precaution



Installation Precautions

WARNING - Several different sources of power can be connected to the fire alarm control panel. Disconnect all sources of power before servicing. Control unit and associated equipment may be damaged by removing and/or inserting cards, modules, or interconnecting cables while the unit is energized. Do not attempt to install, service, or operate this unit until this manual is read and understood.



CAUTION - *System Reacceptance Test after Software Changes.* To ensure proper system operation, this product must be tested in accordance with NFPA 72 after any programming operation or change in site-specific software. Reacceptance testing is required after any change, addition or deletion of system components, or after any modification, repair or adjustment to system hardware or wiring. All components, circuits, system operations, or software functions known to be affected by a change must be 100% tested. In addition, to ensure that other operations are not inadvertently affected, at least 10% of initiating devices that are not directly affected by the change, up to a maximum of 50 devices, must also be tested and proper system operation verified.

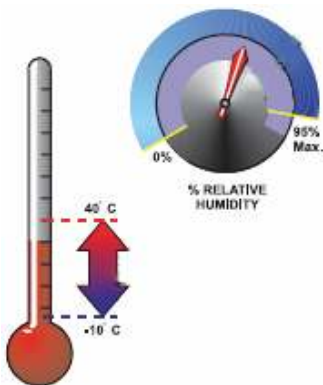
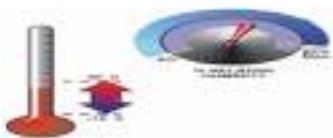

This system meets NFPA requirements for indoor dry operation at 0-49° C/32-120° F and at a relative humidity of 93 ±2% RH (non-condensing) at 32 ±2° C /90 ±3° F. However, the useful life of the system's standby batteries and the electronic components may be adversely affected by extreme temperature ranges and humidity. Therefore, it is recommended that this system and all peripherals be installed in an environment with a nominal room temperature of 0-49° C / 32-120° F.

Verify that wire sizes are adequate for all IDC's loops. Most devices cannot tolerate more than a 10% I.R. drop from the specified device voltage.

Adherence to the following will aid in problem-free installation with long-term reliability:

Like all solid-state electronic devices, this system may operate erratically or can be damaged when subjected to lightning-induced transients. Although no system is completely immune from lightning transients and interferences, proper grounding will reduce susceptibility. *Overhead or outside aerial wiring is not recommended, due to an increased susceptibility to nearby lightning strikes.* Consult with the Technical Services Department if any problems are anticipated or encountered.

Disconnect AC power and batteries prior to removing or inserting circuit boards. Failure to do so can damage circuits.

Remove all electronic assemblies prior to any drilling, filing, reaming, or punching of the enclosure. When possible, make all cable entries from the sides or rear. Before making modifications, verify that they will not interfere with battery, transformer, and printed circuit board location.

Do not tighten screw terminals more than 1.0168 N-m.

Over-tightening may damage threads, resulting in reduced terminal contact pressure and difficulty with screw terminal removal.

Though designed to last many years, system components can fail at any time. This system contains static-sensitive components. Always ground yourself with a proper wrist strap before handling any circuits so that static charges are removed from the body. Use static-suppressive packaging to protect electronic assemblies removed from the unit.

Follow the instructions in the installation, operating, and programming manuals. These instructions must be followed to avoid damage to the control panel and associated equipment. FACP operation and reliability depend upon proper installation by authorized personnel.

3.2 Mounting Details

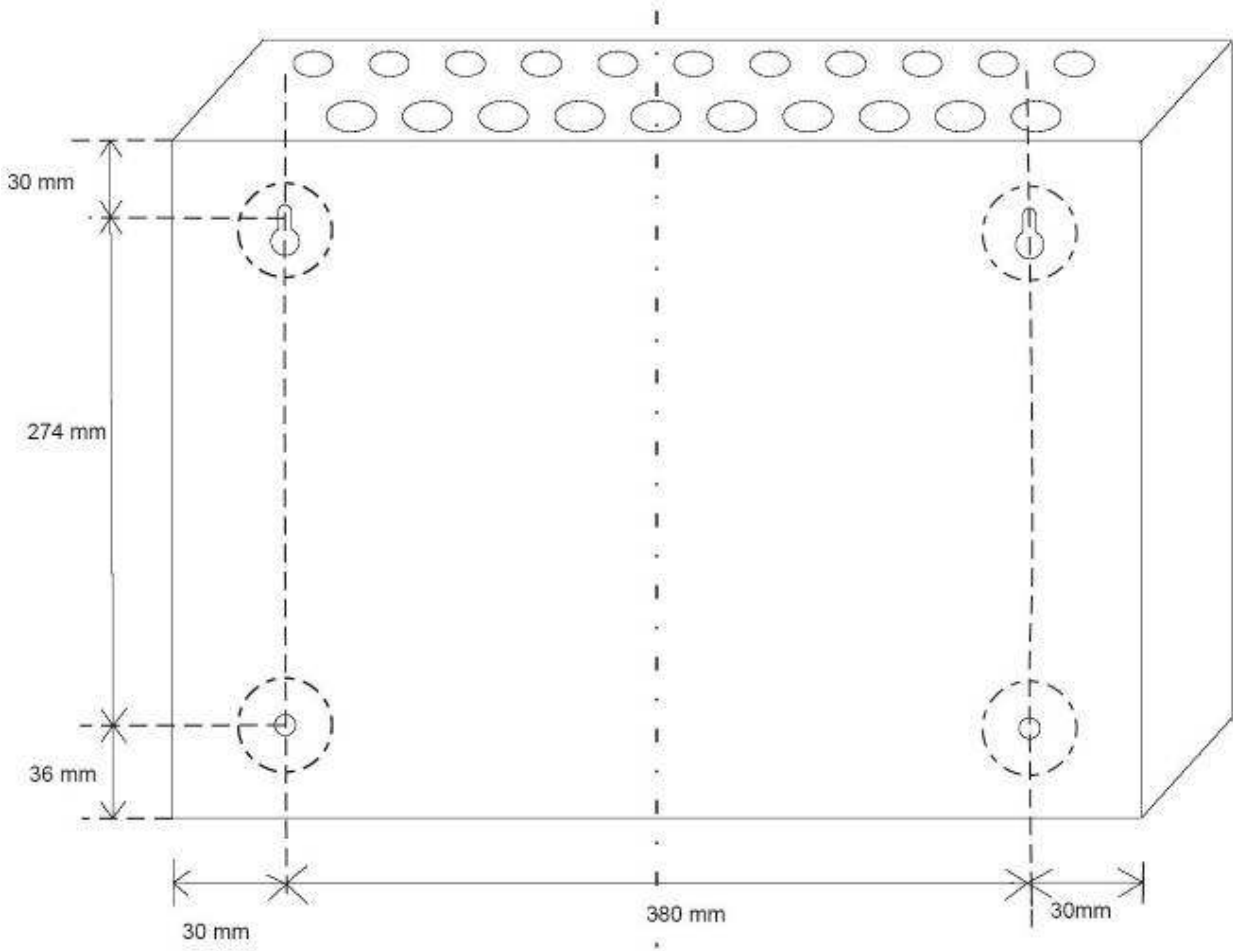

Figure – 9

Remove all the Boards before placing the panel in its mounting position. Place the panel in its mounting position and fix the panel to the wall using the slots of the four screws. Ensure the enclosure and the inner parts of the panel are given sufficient protection during installation. Fix the all boards in its position (Refer Figure24, 25 & 26). All external cables are to be entered via the 20 numbers of $\varnothing 19\text{mm}$ preformed knockouts located at top of the panel.

When the installation of all the cables has been completed, clean the interior of the enclosure ensuring all masonry debris and drilling swords are removed.

3.3 Panel Wiring

Warning: Several different sources of power can be connected to this panel. Disconnect all sources of power before servicing. The panel and associated equipment may be damaged by removing and / or inserting cards, modules or inter connecting while this unit is energized.

Primary Power source (AC) and Earth Ground Connections

AC Power connections are made inside the control panel cabinet. The Primary source for the RE – 2558 / RE - 2554 is 110 - 220 VAC, 50/60Hz, 2.5 Amps. Run a pair of wires with Earth conductor from the protected premises main breaker box to connector CN1 (RE – SMPS – 4A – R1) of the power supply board. As per National Electrical Code, use 14 AWG (2.00 mm², 1.6mm O.D) or heavier gauge wire with 600V insulation. No other equipment may be connected to this circuit. In addition, this circuit must be provided with over current protection and may not contain any power disconnect devices. A separate Earth Ground connection must be made to ensure the proper panel operation and lighting and transient protection. Connect the Earth Ground wire (Min. 14AWG / 2.00 mm²) to the connector CN1.

Standby Power Source (Batteries)

Observe polarity when connecting the battery. Connect the battery cable to connector CN10 on the Zone board (RE – 25XX – ZB – R1) using the connector and cable provided. The battery charger is current – limited and capable of recharging sealed lead acid type batteries upto 12Ah.

During alarm condition, the charger section is disconnected from the battery hence there will not be any charging at that time.

RE – 2558 Power Supply Circuit Board (RE – SMPS – 4A – R1)

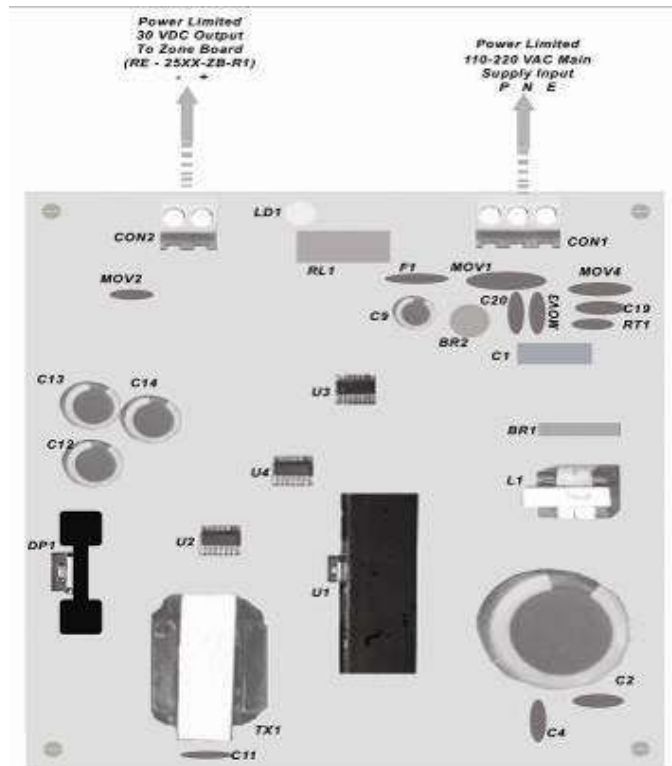

Figure - 10

RE – 2558 Power Supply Monitor Circuit Board (RE –Monitor)



Figure - 11

RE - 2558 Main Circuit Board (RE - 25XX - ZB - R1)

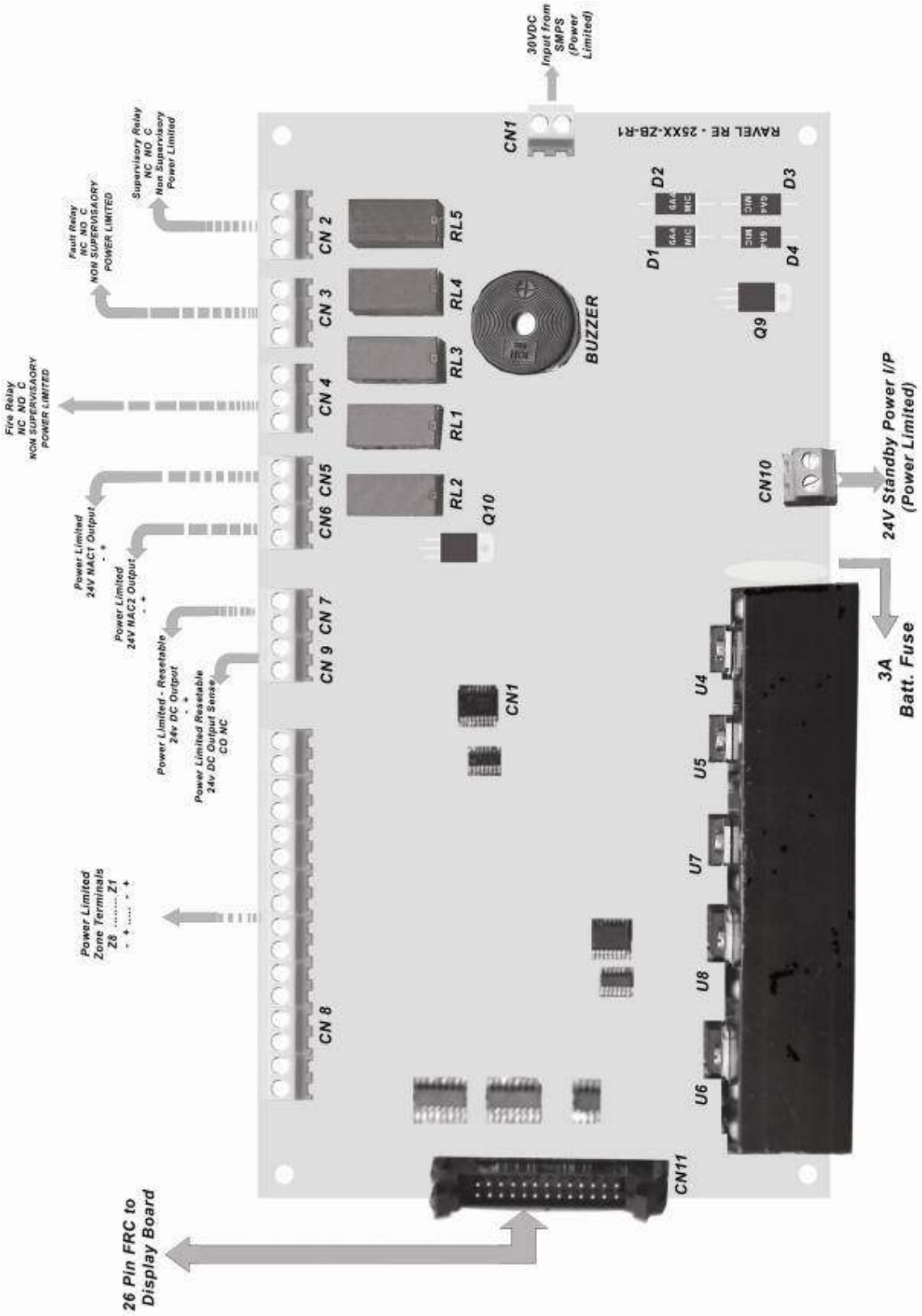

Figure – 12

Field Wiring Diagram



Figure - 13
Mounting OF RE - Monitor

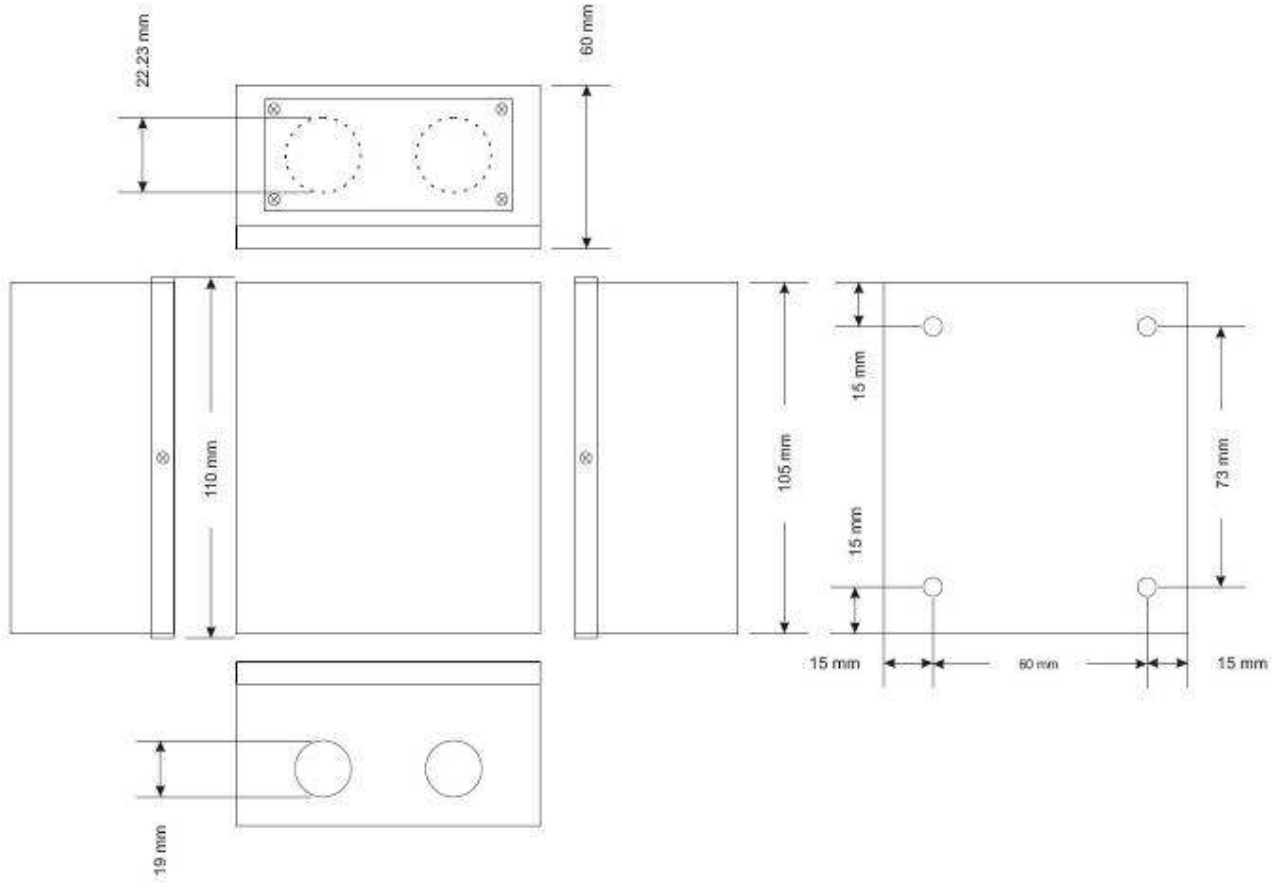

Figure - 14

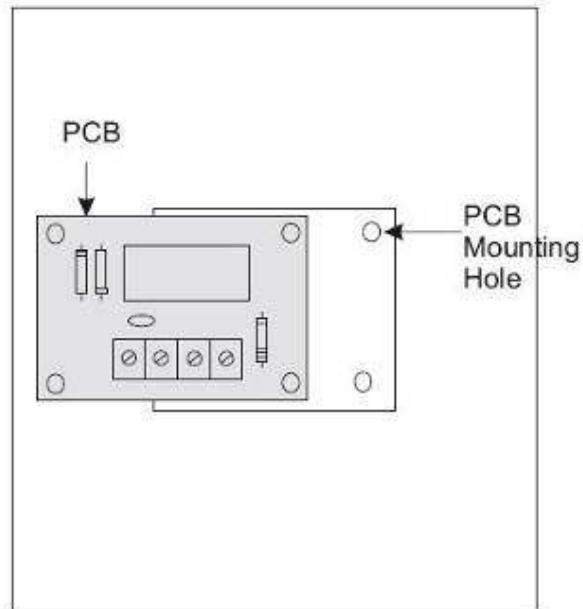

Figure - 15

3.4 Initiating Device Circuit

No. of Initiating circuit:	4 Zone for RE - 2554 8 Zone for RE - 2558
Type	: Class B
Style	: B / C Programmable
Wire Size	: 1.5 sq. mm Max.
Operating Voltage	: 14 - 21 VDC Nominal (Max.)
Terminal	: CN8
Loop Resistance	: 100 Ω Max.
Total No. of Devices	: 20
Monitoring Device	: 3K9 (EOL) (Refer Chapter 9)
Compatible Devices	: Refer Chapter 9.

- ✓ All zones may be configured for general fire alarm applications or supervisory alarm zones.
- ✓ Four-wire smoke detectors may be connected to any zone. Resettable power is provided via CN7.

Note:

- Only smoke detectors can be connected in the zone with alarm verification
- Only Same model detectors should be used in IDC.
- Manual Pull Station should not be used in the style 'C' mode.

Warning: *This unit includes an Alarm Verification Feature that will result in a delay of the system alarm signal from the indicated circuits. The total delay shall not exceed 80 Sec. no other smoke detector shall be connected to these circuits unless approved by the local authority having jurisdiction.*

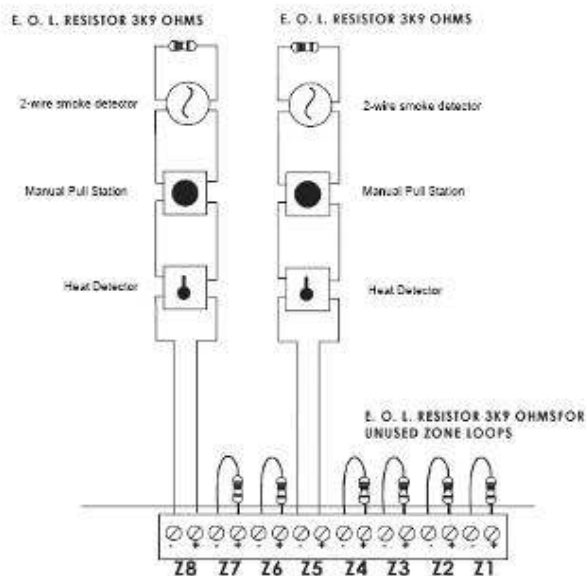

Figure – 16

3.5 Output Circuits

3.5.1 Notification Appliance Circuits

No. of NAC	:	2 Ckts.
Type	:	Class B
Style	:	Y
Current	:	0.6A (Each)
Terminals	:	CN5, CN6
Monitoring Device	:	3K9 (EOL)
Wire Size	:	1.5 sq. mm Max.
Compatible Device	:	Refer Chapter 9.

NOTE:

For Synchronized ANSI Pattern Output External Synchronizing Module to be used. Refer *Chapter 9* for Compatible Devices.

Class B Notification Appliance Circuit (supervised), 3K9 ohms ½Watt

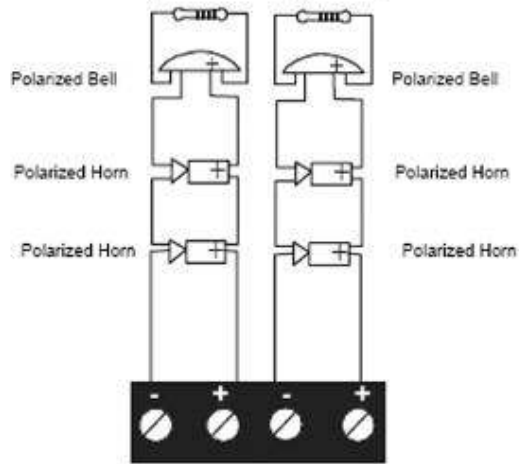

Note: Notification Appliance Circuit polarity shown in alarm state

RETAIN E. O. L. RESISTOR 3K9 OHMS FOR UNUSED CIRCUITS

Figure – 17

3.5.2 24V Output (300mA)

Output Voltage	:	24VDC Nominal
Current	:	0.3A Max.
Output Terminal	:	CN9
Wire Size	:	1.5 sq. mm Max
Monitoring Device	:	RE – MONITOR (Refer Chapter 9)
Monitoring Terminal	:	CN9
CN9 Link	:	3K9 Max. (Refer Chapter 9)

NOTE:

The Link should be disconnected after connecting monitoring device.

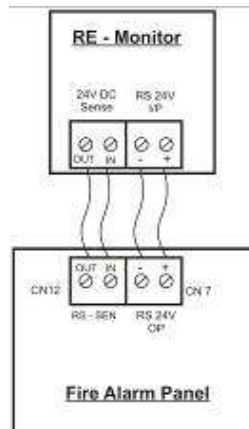

Figure – 18 (Resettable O/P)

3.6 Standard Relay Output Circuits

No. of Relay Output : 3 (Fire, Fault, Supervisory)
 Contact Voltage : 30 VDC Nominal
 Current Rating : 2A
 Type of Relay : Form – C

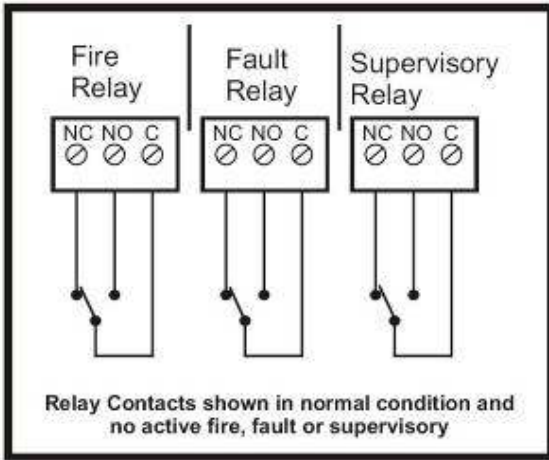

Figure – 19

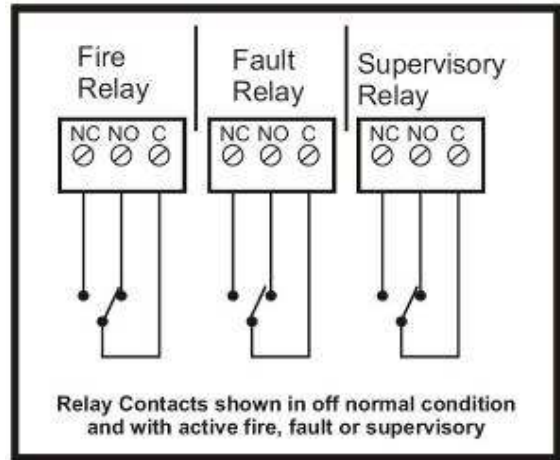
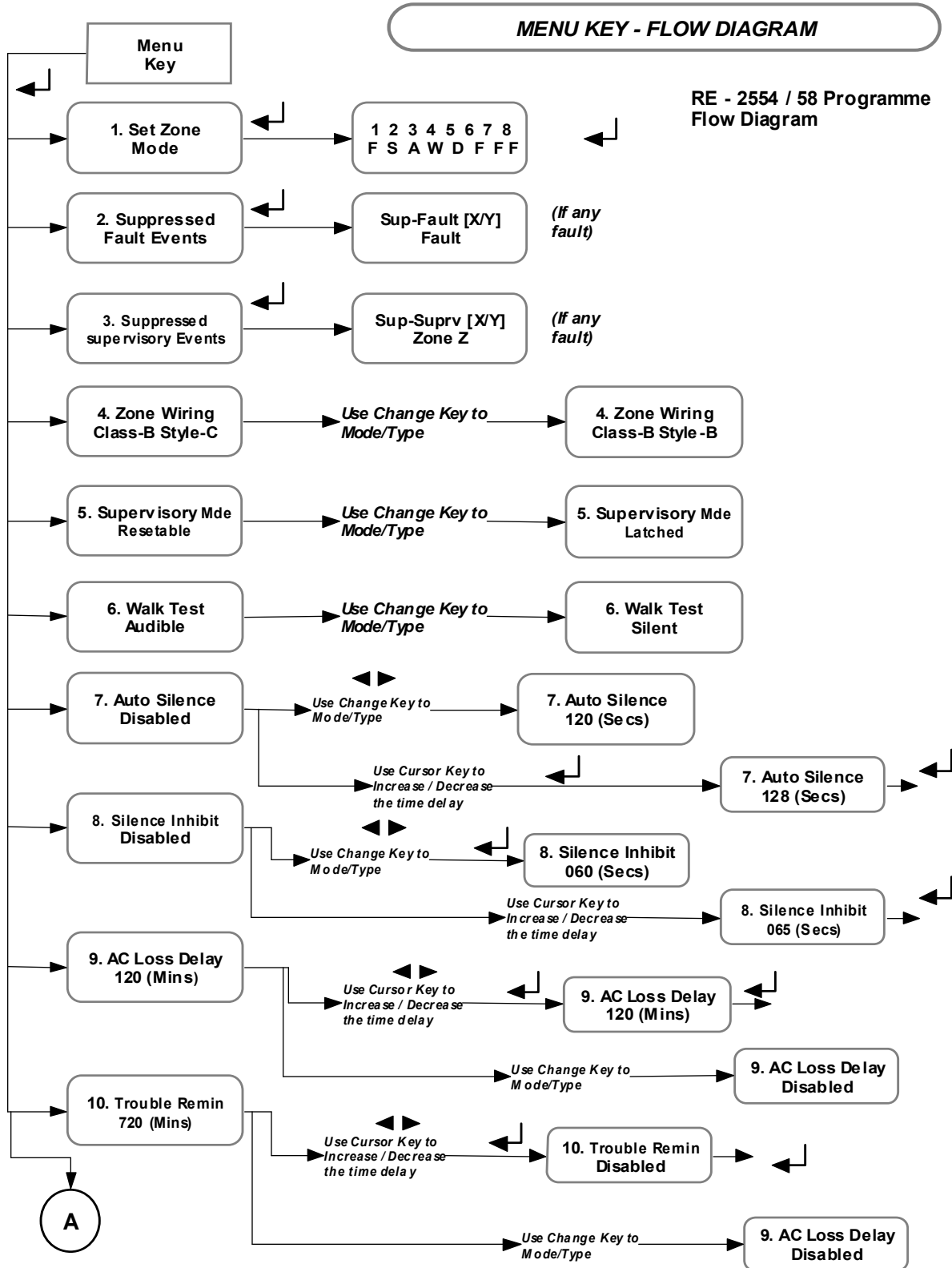

Figure – 20

CHAPTER 4: Programming Instructions

4.1 Menu Key Flow Diagram:



MENU KEY - FLOW DIAGRAM

**RE - 2554 / 58 Programme
Flow Diagram**

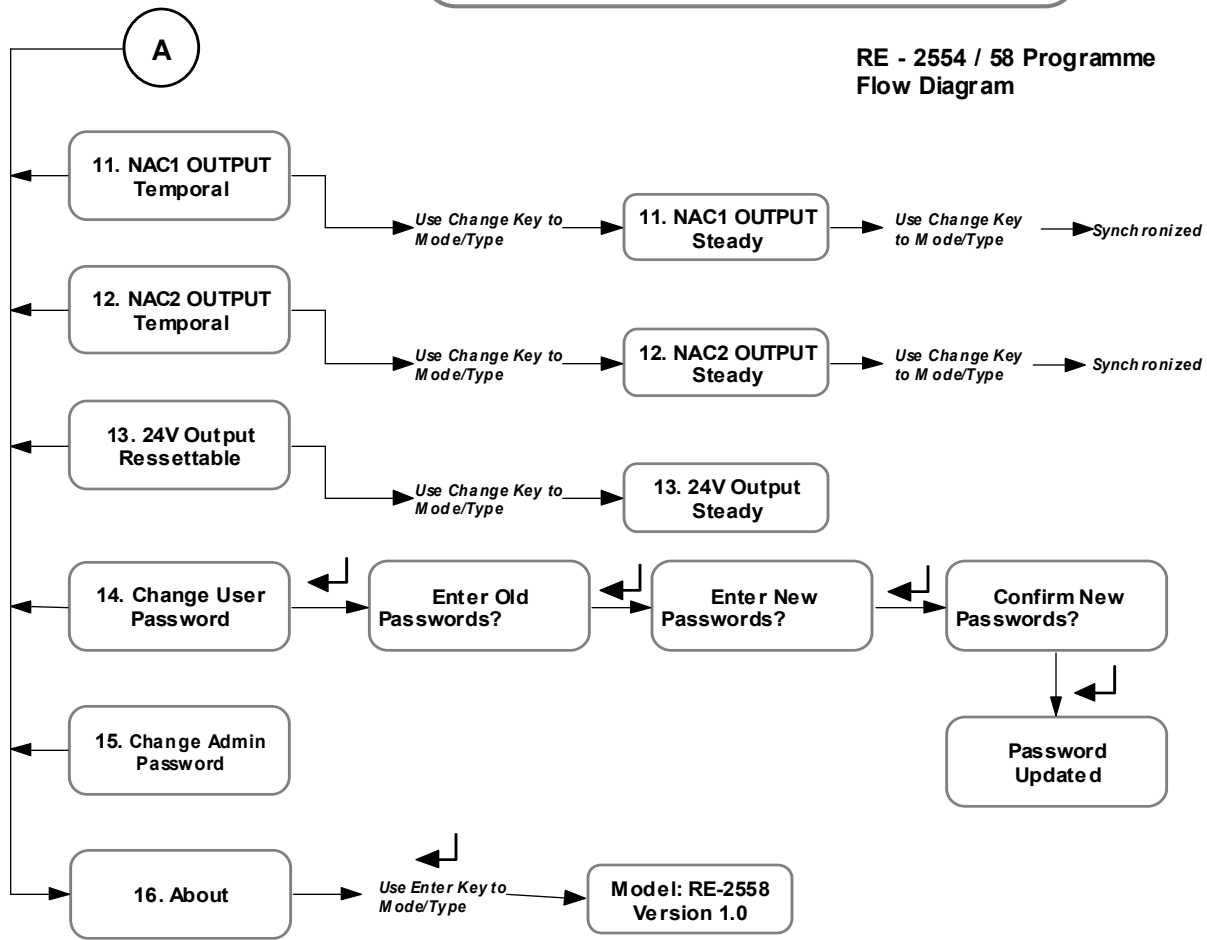

Note:

1. Use Cursor key (◀▶) to move the menu list and to interchange the status of the menu.
2. Use Enter Key (↵) to select the menu list and conform the change of the status.

Figure – 21

4.2 Programming:

The **MENU** key is used to enter into the programming mode for changing the zone details and other settings. The various steps involved in this menu are shown as flow chart 4.1. After entering into the menu, screen will show the first menu as below,

1. Set Zone Mode

To move the other / next menu use the left / right cursor key, and press the enter key to change the settings.

The programmable menu list is as follows.

1. Set Zone Mode
2. Suppressed Fault Events
3. Suppressed Supervisory Events
4. Zone Wiring
5. Supervisory Mode
6. Walk Test
7. Auto Silence
8. Silence Inhibit
9. AC Loss Delay
10. Trouble Remainder
11. NAC1 Output
12. NAC2 Output
13. 24V Output
14. Change User Password
15. Change Admin Password
16. About

4.2.1 Set Zone Mode

From the Set Zone Mode program screen, By pressing the "Enter" key the system enters into the zone set mode. In this mode the zone mode can be changed to supervisory, fire, walktest and disable mode. After entering the zone mode, screen will be as below.

1 2 3 4 5 6 7 8
Y Y Y Y Y Y Y Y

Y = F / S / A / W / D mode.

F – Fire, S – Supervisory, A – Alarm Verification, W – Walk test, D - Disable

The zone is selected by using the right / left arrow keys, the mode can change using the 'Change' key. Then press the "Enter" key to accept the changes. This process can be continued in case of other zone to be changed.

Note:

1. *At the time of Fire/Supervisory events in a fire / supervisory mode set zone, that particular zone mode can only be disabled.*
2. *To come out of the menu configuration press 'Menu' key.*

Fire Mode: In this mode the zone will be in normal condition to detect the fire with detectors and manual pull station (normally open devices). This mode is represented as '**F**' at the time of setting.

Supervisory Mode: In this mode the zone will detect normally open devices. The optional feature of selecting resettable / latching mode. This mode is represented as '**S**' at the time of setting.

Disable Mode: In this mode the zone is disabled with loop voltage cut off. This mode is represented as '**D**' at the time of setting.

Note: *Avoid disabling any zone unless it is really essential.*

Walk test: In this mode the selected zone is used to check all the loop devices manually one by one. The signal from the Initiating device will cause the panel in the alarm mode. The panel automatically get silenced and reset after a specific period without activating the fire relay. In this mode reset is done for only that particular zone. When entering into this mode the Fire relay output disablement is activated automatically and it will go back to previous status while we are coming out from this mode. For other zones that are not in walk test mode, if they sense any fire, then the panel will go to normal alarm mode and walk test zone changed to alarm mode automatically.

This feature helps to perform the testing of devices by a single person. In this mode if the zone detects any fire then after 4 seconds the panel will get automatically silenced. After 2 seconds of silence, the zone will go to reset. This mode is represented as '**W**' at the time of setting.

Note1:

- a. *If there is no more testing, please ensure that the zone is brought back to the normal Condition.*
- b. *To bring back the zone loop to normal condition, same procedure is followed as for the test.*
- c. *If the zone is kept in Walk test mode for 10 minutes with out any test the panel comes out of the walk test mode automatically.*
- d. *During test condition that the other zones that are not in test mode fire will consider as actual fire.*

Note2:

1. *The supervisory mode is selected only in Admin level. And mode changing from supervisory to fire mode is also under admin level.*
2. *After changing the mode should press the ENTER key. Otherwise the change will not accept.*
3. *Avoid disabling any particular zone unless it is giving any false alam / Fault Condition / Reworking*
4. *For zone disabling and their normalization, use same procedure as for the disable.*

Alarm Verification: In this mode, the detectors connected in the selected zone are used to check and confirm that smoke detector activates the verification alarm. The smoke detectors should be connected to the zone which going to select as for alarm verification.

Note:

Use only the alarm verification facility to zone loop in which the smoke detectors are used.

4.2.2 Suppressed Fault Events

From the Suppressed Fault Event program screen, By pressing the “Enter” key the system enters into the Suppressed Fault Event. In this mode the suppressed fault events other than fire events can be viewed sequentially using the right / left arrow keys. After entering the suppressed fault events, screen will be as below.

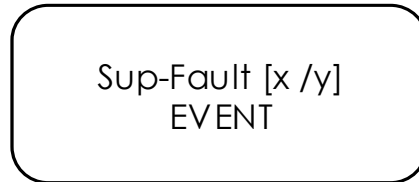

Note: Through suppressed events feature you can view the fault occurred currently during alarm condition.

4.2.3 Suppressed Supervisory Events

From the Suppressed Supervisory Event program screen, by pressing the “Enter” key the system enters into the Suppressed Fault Event. In this mode the suppressed Supervisory events can be viewed sequentially using the right / left arrow keys. After entering the suppressed Supervisory events, screen will be as below.



4.2.4 Zone Wiring

From the Zone Wiring program screen, The zones circuit is designed for the class-B wiring. The style of wiring can be changed using this option. The Style of class-B can be changed as Style-B or Style-C by pressing ‘Change’ key from the panel key pad.

When you enter into this mode the screen will be as below.

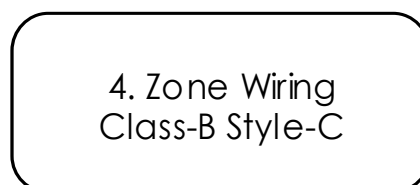

4.2.5 Supervisory Mode

From the Supervisory Mode program screen, The supervisory zones can be selected as resettable / latching mode. Press 'Change' to toggle between options. A supervisory zone, programmed for latching, requires manual reset to restore after the supervisory alarm is cleared. A supervisory zone, programmed for resettable, will be automatically restored after the supervisory alarm is cleared.



4.2.6 Walk Test

In this mode the NAC's can be programmed as Audible / Silenced by using the key 'Change' in this screen. For an audible walktest, the panel detects any fire then after 4 seconds the panel will get automatically silenced. After 2 seconds, the panel will go to reset. This reset is done for only that particular zone. For an silenced walktest, the panel will not activate the NAC's but buzzer tone is activated.

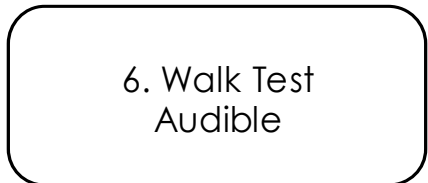

4.2.7 Auto Silence

Auto-silence is the program feature that will automatically silence the Notification Appliance Circuits, if they are programmed as silenceable circuits, after a programmed time interval. The factory default setting is auto-silence disabled. Press 'change' key to toggle between enabled / disabled option.



In auto silence is enabled condition, to change the time press enter key and use left /right key to increase/ decrease the timing.

The Auto silence timing can be set from 001 to 999 seconds. After setting the required time press Enter key to accept the time. The default time set is 120 Seconds. When you enter into this mode the screen will be as below.

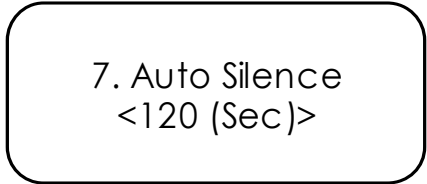

7. Auto Silence
<120 (Sec)>

4.2.8 Silence Inhibit

The Silence Inhibit feature prevents the silencing of Notification Appliance Circuits, using the Silence switch or Reset switch, for the amount of time corresponding to the selected option, after the NAC's are activated. The factory default for this feature is 'disabled'. Press 'Change' key to toggle between enabled / disabled option.



8. Silence Inhibit
Disabled

In silence Inhibit is enabled condition, to change the time press enter key and use left /right key to increase/ decrease the timing.

The Silence inhibit timing can set 1 to 999 seconds. After setting the required time press Enter key to accept the time. The default time is 60 Seconds. When you enter into this mode the screen will be as below.

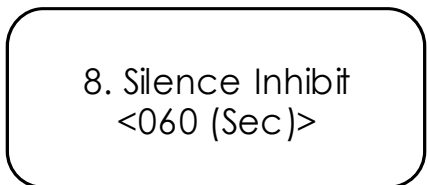

8. Silence Inhibit
<060 (Sec)>

4.2.9 AC Loss Delay

When AC power is lost, the control panel trouble relay will activate. The factory default option for this feature is Enabled, the trouble relay activation on AC loss after the time delay setting. Press 'Change' key to toggle between enabled /

disabled option. The AC Loss Delay timing can set 001 to 999min. After setting the required time press Enter key to accept the time. The default time is 120 Seconds. When you enter into this mode the screen will be as below.

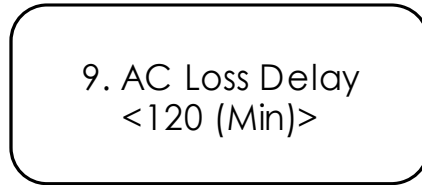

In AC Loss Delay is enabled condition, to change the time press enter key and use left /right key to increase/ decrease the timing.

4.2.10 Trouble Remainder

The Trouble Reminder feature provides an audible reminder that a Fault still exists on the panel after the control panel has been silenced. The factory default for this feature is 'Enabled'. When this feature is 'enabled', the control panel buzzer will give a beep tone for every set time during a trouble condition, after the Signal Acknowledge switch is pressed. The buzzer tone will continue to sound at these rates until the trouble condition is cleared. Press 'Change' key to toggle between enabled / disabled option. The Trouble Reminder timing can set 1 to 999mins. After setting the required time press Enter key to accept the time. The default time is 720 Seconds. When you enter into this mode the screen will be as below.

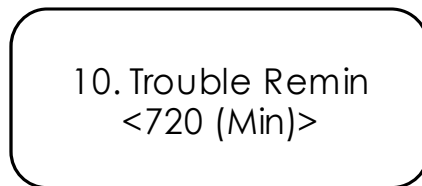

4.2.11 NAC1 Output

The NAC1 output can be configured as steady, Temporal, Synchronized. In Temporal and synchronize mode the NAC1 output will be as pulse as shown below. In these modes all the Sounders will be evacuated simultaneously.

To change the option press 'Change' key to toggle between the options Steady, Temporal, Synchronized. The NAC's should be in off condition to change the options.

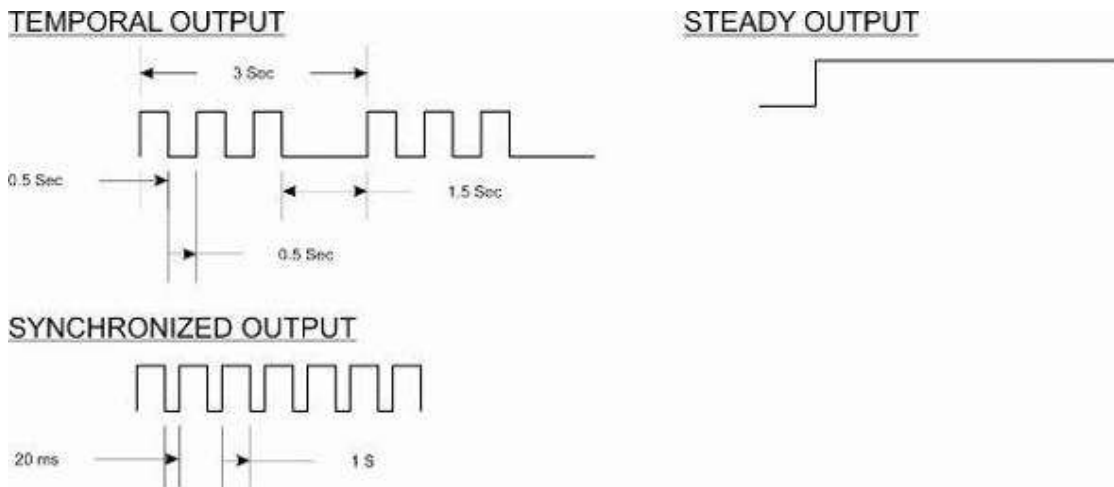

4.2.12 NAC2 Output

The NAC2 output can be configured as steady, Temporal, Synchronized. In Temporal and synchronize mode the NAC2 Output will be as pulse as shown below. In these modes all the Sounders will be evacuated simultaneously.

To change the option press 'Change' key to toggle between the options Steady, Temporal, Synchronized. The NAC's should be in off condition to change the options.

4.2.13 24V Output

The 24V output can be configured as Resettable or steady. If four wire detectors are used in the panel, then the 24V DC output should be configured as Resettable. While resetting the panel this output will cut off for the 3 seconds. . The default setting is Resettable Output. In this mode screen display as below.

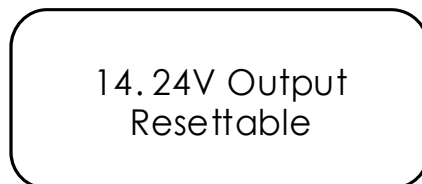

To change the option press 'Change' key to toggle between the options Steady and resettable.

4.2.14 Change User Password

From the Change User Password Mode screen, By pressing the 'enter' key from the change user Password screen, system enters into the user Password change mode. The display screen of this mode showed as below. The Default Password is "1234". The Password should be four digit.

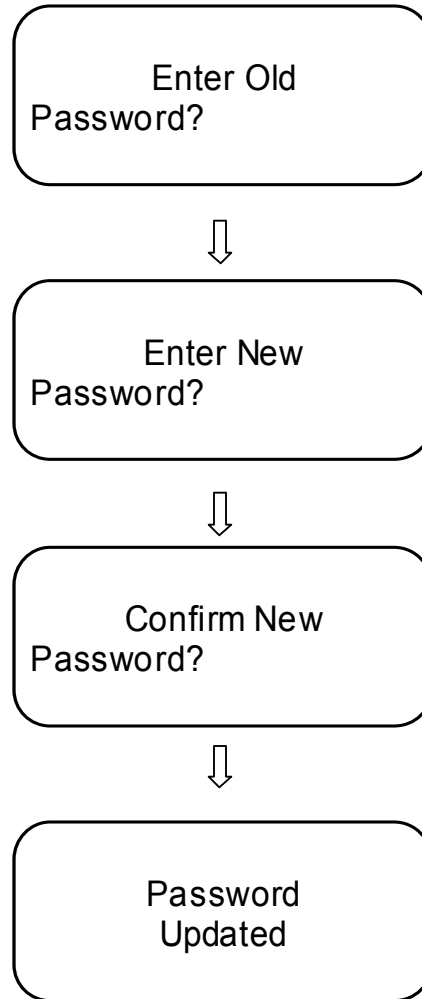

4.2.15 Change Admin Password

From the Change Admin Password Mode screen, By pressing the 'enter' key from the change Admin Password screen, system enters into the Admin Password change mode. The display screen of this mode showed as below. The Default Password is "54321". The Password should be five digit.

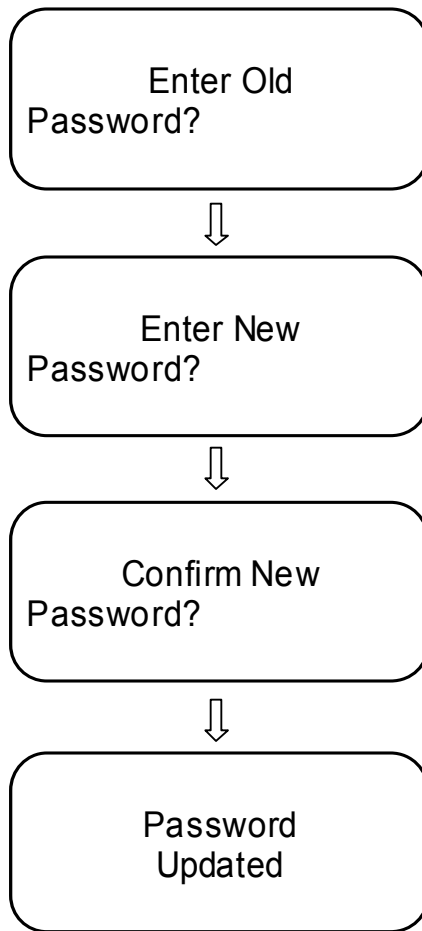

Admin Password can be changed only by entering into the main menu by using the admin password.

4.2.16 About

It shows the details of the panel by pressing enter key in the about menu. The LCD will show as below. The model shown with respect to the no. of zones, for 4 zone RE – 2554 and for 8 zone RE – 2558.

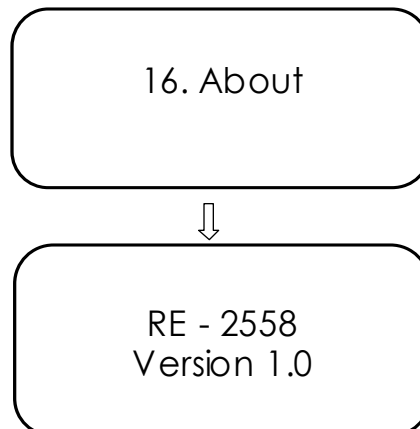

Note: Version shown is software version.

Chapter 5: Operating Instruction

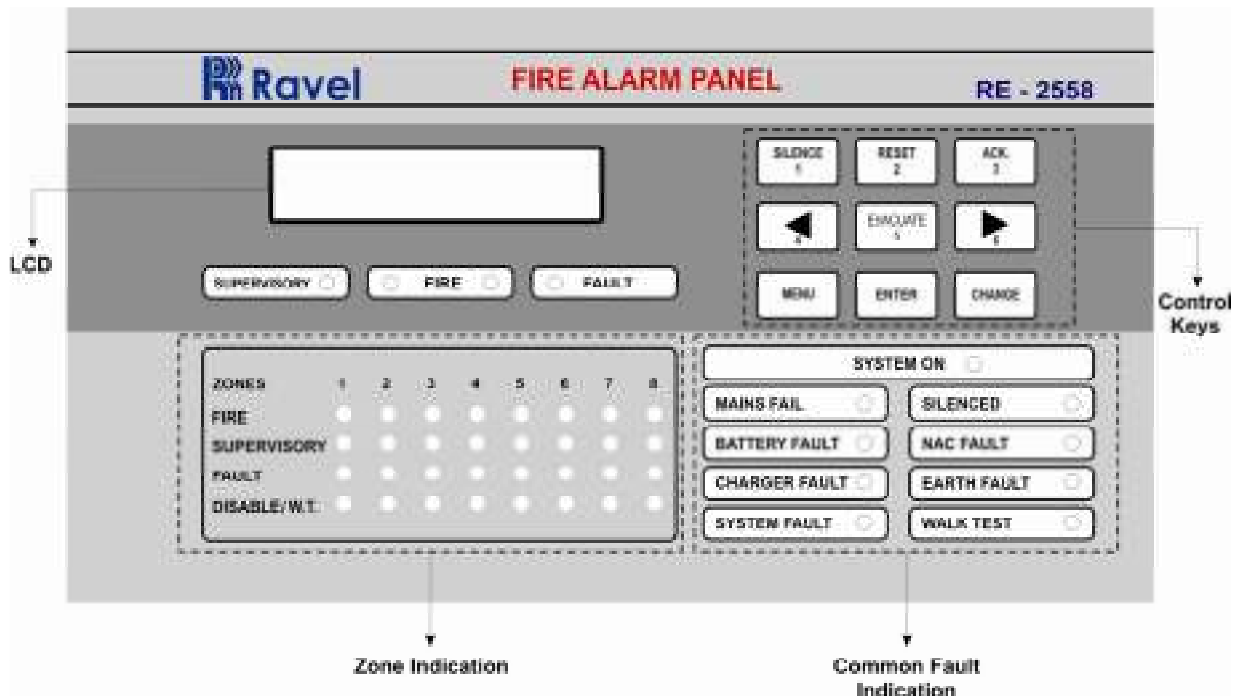

Figure – 23

5.1 Switch Functions

The Keys, which are non-masked, are used for the general operation of the Fire Alarm Panel. The Non-masked keys are Silence, Reset, Ack., Evacuate and Enter keys.

SILENCE Key: When the silence key is pressed, after entering the user or admin password the following will occur:

- The silenceable Notification Appliance Circuits will be turned OFF
- The Silence LED will be turned ON

Upon the occurrence of a subsequent fire event, Signal Silence is overridden and the control panel will respond to the new event.

RESET Key: When the Reset key is pressed, after entering user or admin password, the control panel will:

- Clear the status LED's.
- Bring back the LCD display to the healthy condition.
- Turn off the Notification Appliance Circuits.
- Reset fire zones by temporarily removing power.
- Restore all system relays to normal.
- Temporarily remove power from the resettable power output CN7.

The Reset key is accessible only after silencing in alarm condition. Any alarm, supervisory or trouble condition that exists after a system reset, will resound the system, reactivating normal system activity.

ACK. Key: This key is used to acknowledge the buzzer tone during the fault and fire condition. This key can be operated with user or admin password.

EVACUATE Key: This key is used to energize the all-external NAC's without actual fire, It will operate at user or admin level. Using the silence key NAC output can be silenced.

ENTER KEY: This key is used to accept the entries and edit the programmed menu.

MENU Key: This key is used to get into the program menu and get back to the previous menu screen.

CURSOR KEYS: The cursor keys (Right / Left arrows) are used to move the cursor point wherever required.

CHANGE KEYS: These key is used to change the status of modes. And to clear the password entries.

5.2 Indications:

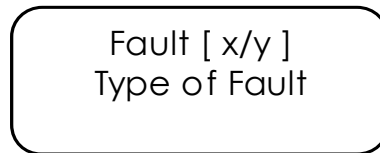

x – n^{th} no. of fault; y – Total no. of fault.

Figure – 22

SYSTEM ON: This LED will glow when the panel is energized by primary and standby power. This is the only LED glowing in the normal monitoring condition. The LCD Display as shown below.

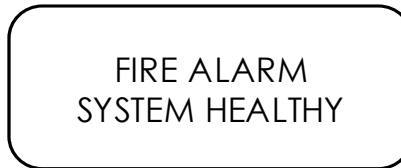

MAINS FAIL: Whenever the Main Supply (110 - 220v A.C) fails, the Mains fail LED will be illuminated and it also indicated in LCD with toggle Buzzer tone. The LCD Display as shown in the figure 22, 'Mains fail' will be displayed in the fault screen.

BATTERY FAULT: Whenever the backup battery fails, the battery fault LED will be illuminated and it also indicated in LCD with toggle Buzzer tone. Similarly the same LED will be illuminated when the battery voltage goes down below the 21.6v (Battery Low). The LCD Display as shown in the figure 22 'Battery Fail / Battery Low' will be displayed in the Battery fail / Battery low fault screen respectively.

CHARGER FAULT: Whenever the battery charger section is fails, the charger fault LED will be illuminated and it also indicated in LCD with toggle tone.

EARTH FAULT: Whenever the Initiating Device circuits (IDCs) and Notification Alarm Circuits (NACs) are gets contact with the Earth or Body of the cabinet, the corresponding fault LED, earth fault LED and common fault LED will be illuminated and it also indicated in LCD as corresponding circuit is earth fault with toggle Buzzer tone. The Earth fault can be created through 0 Ohms resistor.

SYSTEM FAULT: Glowing of this LED indicates the failure of the CPU.

SILENCED: This LED will glow when the silence key is pressed in fire condition only.

NAC FAULT: Whenever there is any fault in Notification Appliances Circuits like NAC loop Open / Short / Earth fault, it will be identified by COMMON NAC FAULT LED. The LCD Display as shown in the figure 22, 'NAC # Fault' will be displayed in fault screen.

WALK TEST: The Walk test and zone disable LED will glow whenever the zones are under walk test mode.

FIRE: This twin fire LED will glow when any one or more of the zones are in fire condition.

SUPERVISORY: This supervisory LED will glow when any one or more of the zones are in supervisory condition.

FAULT: This fault LED will glow when any one or more of the zones are in fault condition.

ZONE FIRE: This fire LED will glow when the zones are fire condition. The first fired zone continuously in blink and other zone fire LED will glow steadily in fire condition. The fired zone is displayed in the LCD, first fire zone and total no. of zone is displayed separately.

ZONE SUPERVISORY: The zone supervisory LED is illumination indicates that the particular Zone is selected as Supervisory zone (Contact Zone). During supervisory fault condition the same LED starts blinking.

ZONE FAULT: This fault LED will glow when there is an open or short or earth fault in that particular zone.

ZONE DISABLE/W.T: This zone wise LED glows steadily in disabled condition and blinking in the Walk test mode.

5.3 Operation

5.3.1. Normal Monitoring Mode:

Normal Mode is the standard mode of operation. In this mode, the panel continuously monitors system status. When no fire or supervisory or trouble conditions exist, all LEDs will be off except the System On LED. The Notification Appliance Circuits will be off, all relays are in their normal state and the onboard buzzer will be off. When the system is in normal condition the LCD screen will be as below.



5.3.2. Fire Alarm Condition:

When the control panel detects Fire via the Detector / MCP, the panel will cause the following:

- ✓ The corresponding ZONE FIRE red LED will blink.
- ✓ The common twin Fire LEDs will glow.
- ✓ Turn on the NAC's.
- ✓ Turn on the panel buzzer with continuous tone.
- ✓ Turn on the fire relay.

The LCD screen will be as below.

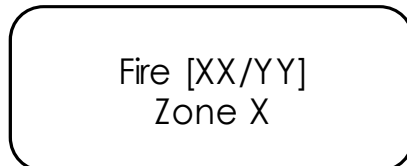

In case of multiple zone fire, the origin zone fire LED will be blinking and subsequent zone fire LED will glow steadily. The LCD screen will be as below.

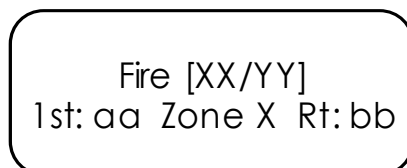

X – index no. of fire event; **Y** – Total no. of fire events;

aa – Origin Fire zone number; **bb** – Recent Fire zone number;

Zone **X** – Denotes the zone number which is recent fire zone.

To change the other indexed fire event zones which are suppressed use right / left arrow keys.

Restoral: Silence the NAC's by appropriate user or admin password. after silencing the panel will perform the following;

- Turn off the Internal Buzzer.
- Turn off the External NAC's.
- Turn on the silenced LED.

When the Fire condition is cleared and Reset key has been pressed after entering the user or admin password. The Reset is accessed only after silencing the panel in alarm condition. The panel will perform the following after clearing fire and resetting:

- Turn off the common twin Fire LEDs.
- Turn off the zone fire LED.
- Turn off the Fire relay.

The LCD screen will be as below.

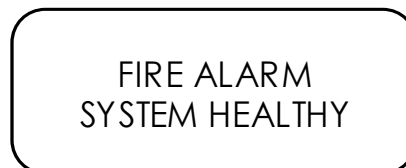

5.3.3. Supervisory:

When the control panel detects supervisory signal via the any normally open contact devices, the panel will cause the following:

- ✓ The corresponding zone supervisory LED will blink.
- ✓ The common supervisory LED will glow.
- ✓ Turn on the panel buzzer with intermittent buzzer tone (pulse 0.25sec ON and 0.25sec OFF).
- ✓ Turn on the supervisory relay.

The LCD screen will be as below.

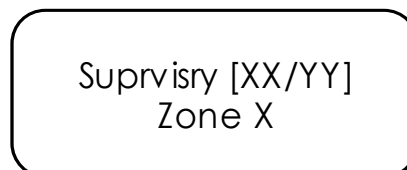

In case of multiple zone supervisory, the origin zone and recent zone supervisory LED will be viewed in LCD screen. The LCD screen will be as below.

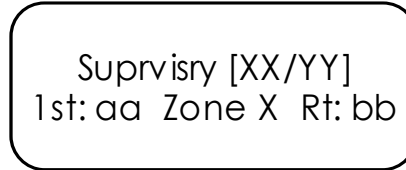

Suprvisry [XX/YY]
1st: aa Zone X Rt: bb

X – index no. of supervisory event; **Y** – Total no. of supervisory events;
aa – Origin supervisory zone number;
bb – Recent supervisory zone number;
Zone **X** – Denotes the zone number which is recent fire zone.

To change the other indexed supervisory event zones which are suppressed use right / left arrow keys.

Restoral: When the supervisory condition is cleared and Reset key has been pressed after entering the user or admin password if the zones are programmed for latching, the panel will perform the following:

- Turn off the supervisory LEDs.
- Turn off the zone supervisory LED.
- Turn off the supervisory relay.

The LCD screen will be as below.



FIRE ALARM
SYSTEM HEALTHY

Note:

If the supervisory mode is selected as resettable, the resetting the zone is not required. The zone is retrieved automatically after clearing the supervisory condition.

5.3.4. **Fault:**

The fault may any one of the following Zone fault / disable / earth fault, NAC fault and power section fault. When there is one or more fault condition, the fire alarm control panel performs the following:

- Turn on the common fault LED.
- Turn on the zone fault / NAC fault / power fault LED.
- Turn on the panel buzzer tone with intermittent buzzer tone (pulse 0.5sec ON and 5sec OFF).
- Activate the fault relay.

The LCD screen will be as below .

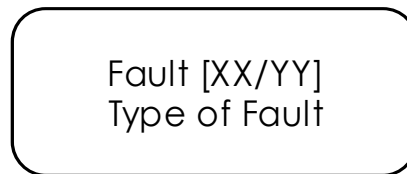

XX – nth no. of events; **YY** – Total no. of events.

Restoral: When the fault condition is cleared, the panel will perform the following automatically:

- Turn off the fault LEDs.
- Turn off the zone fault LED/ NAC fault / power fault LED.
- Turns off the buzzer tone.
- Deactivate the fault relay.

The LCD screen will be as below .

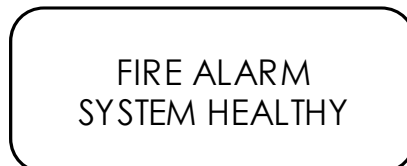

Note: The Fault occurred will not affect the other normal functions of the panel

5.3.5. **Disable/W.T:**

Disable: The any Zone can be Disabled / Enabled in zone mode through the programming section [4.2.1 Page 35](#). The ON status indicates, the zone is disabled and the OFF status of the LED indicates the enabled and blinking of that LED indicates the zone is in walk test mode. In LCD the suppressed events are viewed in suppressed events from menu screen.

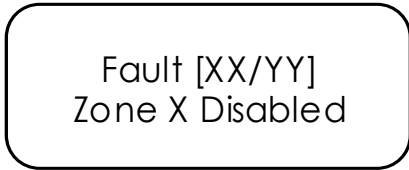

XX – nth no. of events; **YY** – Total no. of events; **X** – Zone No. Disabled.

Walk Test: Disable/W.T LED Blinking identifies the corresponding Zone, which is under walktest. If this LED is illuminates continuously then it identifies that particular zone is disabled. The walk test mode helps the user to test each device in that particular zone by a single person. During walk test mode, if any Fire is identified, the panel will be silenced and reset automatically after 4 seconds and 2 seconds respectively. In case of any other zone fire during this period, it is considered as actual fire and it comes out from the walk test mode. The LCD Display is as shown below.

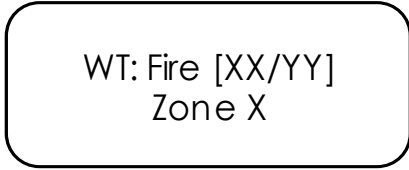

For More than One zone in Walk test fire condition, the screen as follows,

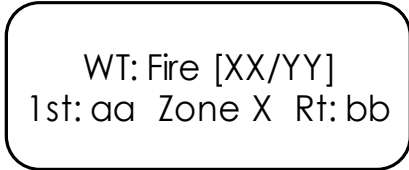

Note:

- a. *If there is no more testing please ensure that the zone is brought back to the normal Condition.*
- b. *During in this mode, the Fire Relay will not be activated while in fire condition.*
- c. *If the zone is kept in Walk test mode for 10 minutes with out any test the panel comes out of the walk test mode automatically.*
- d. *In other zone gets fire, the walk test mode automatically removed.*

Restoral: When the zone restored to normal condition from disable / Walk test mode, the zone which are all in disable/W.T mode the corresponding LED's goes off.

5.3.6. Alarm Verification:

This Alarm verification feature is applicable only to the IDC's in the zone in which only smoke detectors are used.

If the alarm verification is selected IDC, the smoke detector activation will cause the FAP to reset the detector by removing the power for 3.5 Seconds. Power is reapplied to the detectors and restart period 12 Seconds begins to stabilize all the detectors. If no other detector alarm, there will no alarm indication in FAP during Retard - Reset - restart period. During the conformation period of 60 seconds, the subsequent alarm in the same detector will cause FAP to activate immediately appropriate outputs and indicates alarm indication in the FAP. During this conformation period or Reset & Retard period, if there is any alarm in other zone, the panel activates immediately appropriate outputs in FAP.

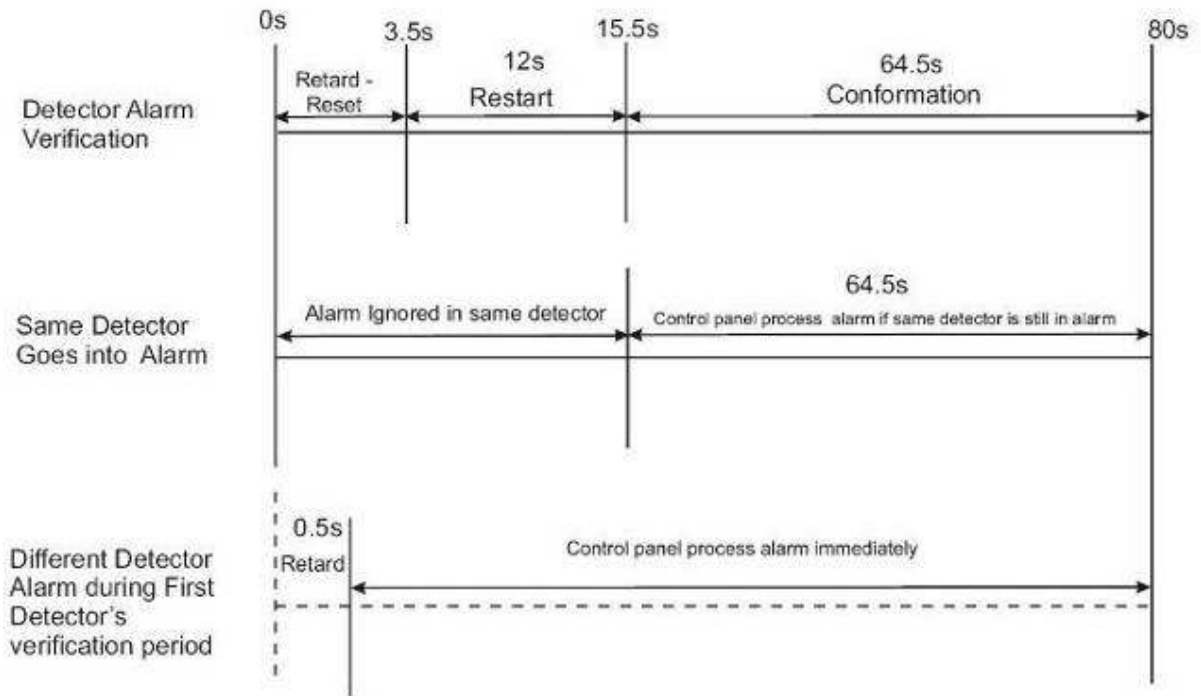

Note: Alarm Verification is available for only smoke detectors connected zones

Figure - 24

Chapter 6: Servicing:

6.1 Installation/Replacement of PCB:

Remove the screws of PCB, which has to be change and remove the PCB from the mounting position and place the new PCB in that same position as shown below.

Mounting position for Main Circuit board (RE – 25XX – ZB – R1):

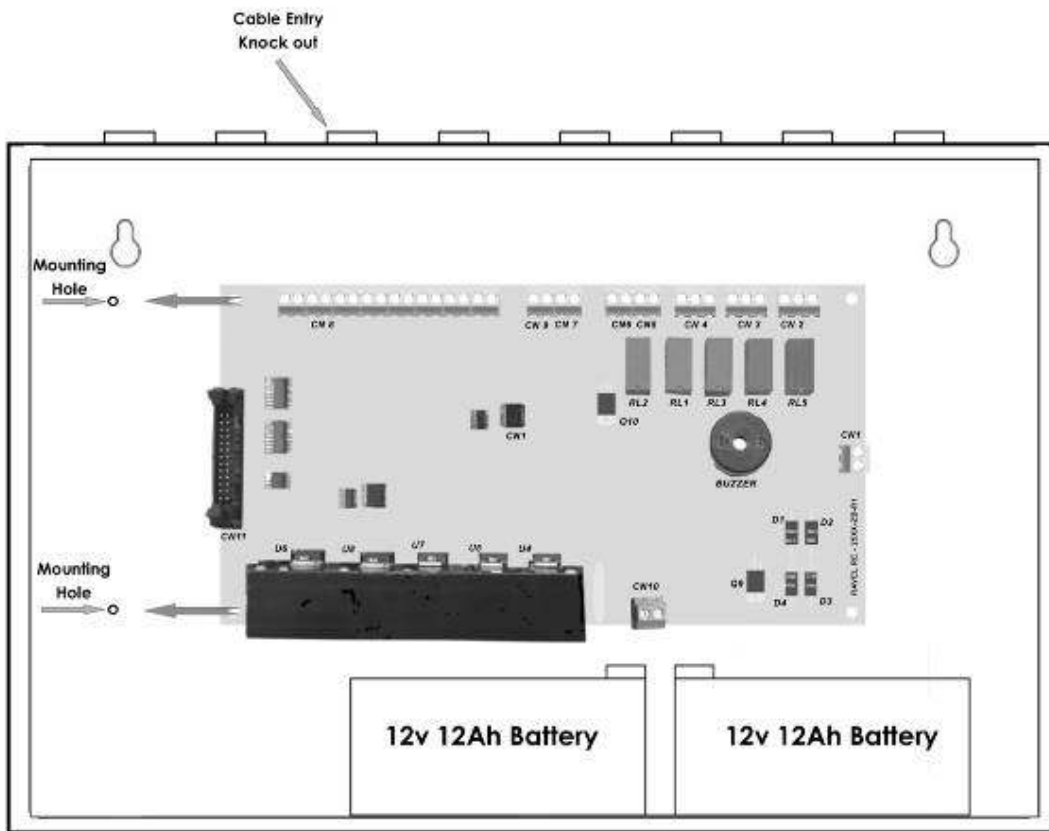

Figure – 25

Mounting position for Display board (RE – 2558-54 – DISP – R1):

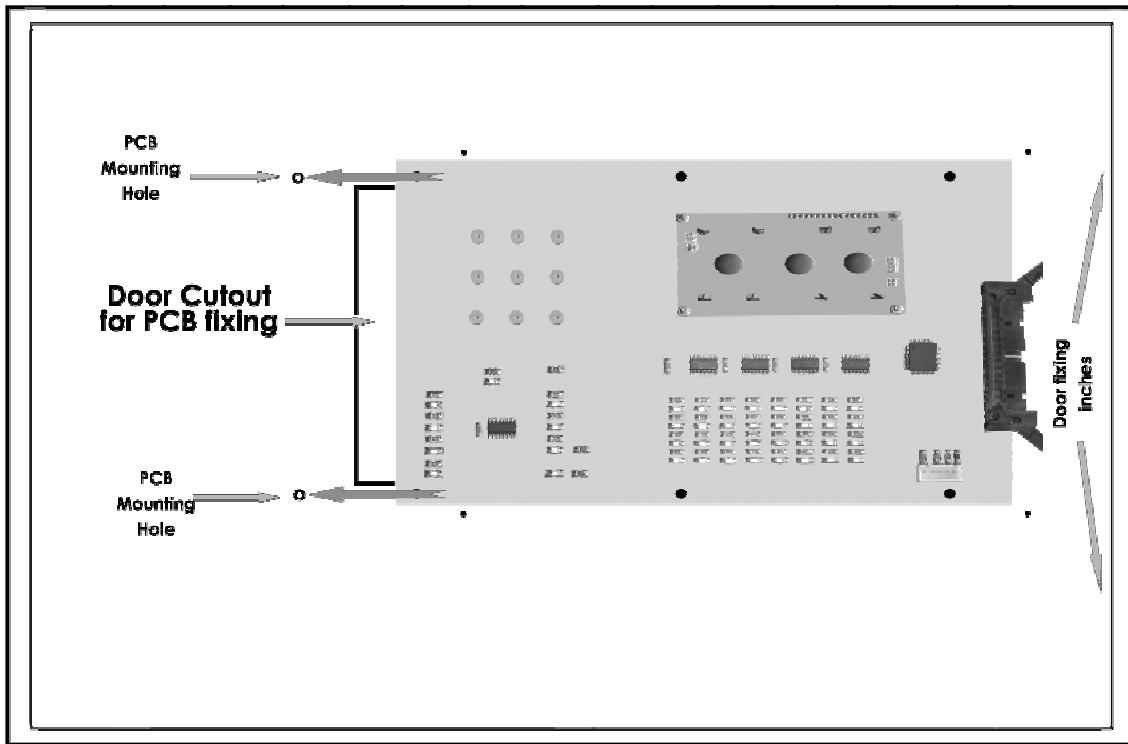

Figure – 26

Mounting position for Power supply unit (RE – SMPS – 4A – R1):

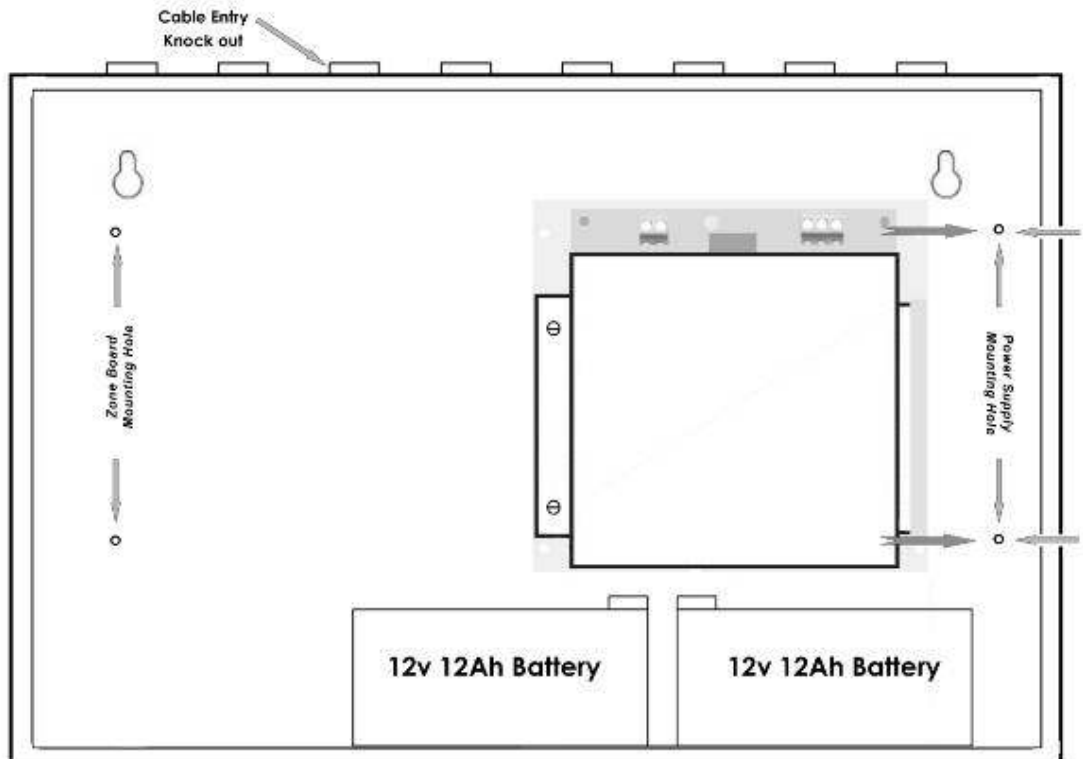

Figure – 27

6.2 Lamp Test:

The lamp test function done by pressing 'Enter' key in system (Panel) is normal condition. In this mode, all the LED's are checked for good condition by glowing all LED's.

6.3 Walk Test Mode:

The RE – 2558 provides the capability to perform a walktest of the system without triggering the Fire Relay, alarm output (NAC) relay. Walk test Mode allows for testing of all the eight zones. An audible or silent walktest may be performed.

For an audible walktest, the initiating device activated on a zone will cause the Notification Appliance Circuits to turn on for five seconds. Any smoke detectors that are activated will be reset automatically. Zonal faults (open circuits) will cause the NAC to remain on steadily. Prior to entering Walktest Mode, check to be certain that zone fault have been cleared.

Placing the control panel into Walktest Mode will only be possible if the system has no active alarms.

After entering into the walktest mode, the fire relay contact disablement is activated automatically and it will go back to previous status while we are coming out from this mode. For other zones that are not in test condition, if they sense any fire, then the Fire relay output will activate by considering it as actual fire.

This feature helps to perform the testing of devices by a single person. In this mode if the panel detects any fire then after 4 seconds the panel will get automatically silenced. After 2 seconds of silence, the panel will go to reset. This reset is done for only that particular zone.

Once in Walktest Mode, the control panel will immediately:

- Turn on the Notification Appliance Circuits for 4 seconds for the alarm on a zone if an audible walktest is performed. For a silenced walktest mode, all NAC outputs remain off.
- Disable the fire relay
- Display all alarm conditions as they occur

- Display all zone troubles as they occur
- Display all system troubles as they occur

Note:

1. If any one zone is in walktest, then other zones will operate normal condition.
2. The actual alarm zone cannot be selected for walktest mode.
3. By Reset the panel using the reset key then walktest selected zone goes to fire mode.

6.4 System Power:

Power	Current	Max. AH Capacity	Derating Factor	Max. standby current	Max. Alarm current	Max. standby time	Max. alarm duration
Primary (power supply)	2.5A	N/A	N/A	0.04A	0.4A	N/A	N/A
Secondary (back up)	2.3A	12Ah	10%	0.4A	2.3A	24 Hrs.	5 Min.

6.5 Trouble Shooting:

Condition	Root Cause	Remedy
There is no indication on the panel	No power to the Panel	Check Primary (AC) power and Standby power.
During Mains fail condition Battery fault LED is glowing	May be battery low (<21.6V) or the battery reaches the de-rated (<19.5V) Voltage.	Check the Battery voltage and charge the battery or replace the battery.
The Battery fault and charger fail shown in LCD.	The Battery connected in reverse.	Connect the battery properly.

Chapter 7: Battery Calculation

Use Table 7.4 to calculate the total standby and alarm load in ampere hours (AH). This total load determines the battery size (in AH), required to support the control panel under the fail of the AC Power Supply. Complete the table 7.4 as follows:

1. Enter the NFPA standby and alarm times (refer to NFPA requirements below).
2. Calculate the ampere-hours for standby and Alarm, and then sum the standby and alarm ampere-hours.
3. Multiply the sum by the derating factor of 1.2 to calculate the proper battery size (in AH).
4. Write the ampere hour requirements on the protected premises label located inside the cabinet door.

TABLE 7-4: Total Secondary Power Requirements at 24 VDC

Normal Condition : $X = \mathbf{S}$ (Amps) x ____ Hrs. (Backup time required)

Alarm Condition : $Y = \mathbf{F}$ (Amps) x ____ Hrs. (Backup time required)

Battery Ah required : $AH = (X + Y) \times 1.2$ (Derating Factor).

Note: Refer specification (Page 10) for Quiescent, standby, alarm currents

System current (**S**) = Quiescent Current +
(Standby current X No. of zone)

Fire current (**F**) = (Alarm Current x no. of zones) +
(NAC Current x No. of NAC's).

Chapter 8: Wire Requirements

Connecting external system accessories to the RE - 2558 main circuits must be carefully considered to ensure proper operation. It is important to use the correct type of wire, wire gauge and wire run length per each RE - 2558 circuit. Reference the chart below to specify wire requirements and limitations for each RE - 2558.

TABLE 8-1: Wire Requirements

CIRCUIT TYPE	CIRCUIT FUNCTION	WIRE TYPE AND LIMITATIONS	RECOMMENDED MAX. DISTANCE Feet (meters)	WIRE GAUGE
Initiating Device Circuit	Connects to Initiating Devices	Untwisted, unshielded wire (Do not exceed 100 ohms)	10,000 (3,000 m) 8,000 (2,400 m) 4,875 (1,480 m) 3,225 (975 m)	12 AWG (3.25 mm ²) Belden 9583 WPW999 14 AWG (2.00 mm ²) Belden 9581 WPW995 16 AWG (1.30 mm ²) Belden 9575 WPW991 18 AWG (0.75 mm ²) Belden 9574 WPW975
24 VDC resettable, nonresettable	Connects to annunciators and other accessories	No more than 1.2 volt drop allowed from supply source to end of any branch	Distance limitation set by 1.2 volt maximum line drop	12 AWG (3.25 mm ²) - 18 AWG (0.75 mm ²)

Chapter 9: Compatible Devices (ID: CD 01)

The compatible devices which are connected with this panel are given below:

Compatible IDC's:

1. Apollo 65A Series – Model: 55000-226 - 16 Nos / Zone.
2. System Sensor 100 Series – Model: 2151 - 16 Nos / Zone.
3. System Sensor Beam Smoke Detector – Model: BEAM1224(S)
- 1No / Zone.

Compatible NAC's:

1. System Sensor Mini Horn – Model: MHR / MHW – 30 Nos / Circuit.
2. System Sensor Strobes – Model: MHR / MHW – 9 Nos (@15cd setting) / Circuit.

End Of Line Devices:

1. RE – Monitor for RS24v O/P.
2. RE3K9 for IDC's, RS sen and NACs.

Chapter 10: Abbreviation

The short forms, which are given in this manual, are abbreviated below,

RE	-	Ravel Electronics Pvt Ltd.,
NFPA	-	National Fire Protection Association
AC	-	Alternating Current
DC	-	Direct Current
CRCA	-	Cold Rolled Carbon Alloy
LED	-	Light Emitting Diode
O/P	-	Output
mm	-	millimeter
no(s).	-	number(s)
P	-	Phase
N	-	Neutral
E	-	Earth
v	-	volt(s)
Ah	-	Ampere per hour
IEE	-	Institute of Electrical Engineering
EOL	-	End Of Line
PCB	-	Printed Circuit Board
CPU	-	Central Processing Unit
MCP	-	Manual Call Point
S.Nos	-	Serial Numbers
mA	-	milli Ampere
Kgs	-	killo grams
C,NO,NC	-	Common, Normally Open, Normally Close.

Ravel Electronics Pvt Ltd.,

150A, Electronic Industrial Estate,
Perungudi, Chennai – 600096, India.

Web: www.ravelfirepanels.com

Email: marketing@ravelfirepanels.com